

HP Archive

This vintage Hewlett Packard document was
preserved and distributed by

[www. hparchive.com](http://www.hparchive.com)

Please visit us on the web !

Scanned by on-line curator: Tony Gerbic

**** For FREE Distribution Only *****

PRELIMINARY OPERATING MANUAL



MODEL 562A

DIGITAL RECORDER

Serials Prefixed: 134 -

Copyright HEWLETT-PACKARD COMPANY 1961
1501 PAGE MILL ROAD, PALO ALTO, CALIFORNIA, U.S.A.

TABLE OF CONTENTS

Section	Page
I GENERAL DESCRIPTION	1-1
1-1. Description	1-1
1-2. Data Entry	1-1
1-3. Standard Instrument	1-1
1-4. Options Available	1-2
1-5. Power Requirements	1-2
1-6. Uses	1-2
II INSTALLATION	2-1
2- . General Information	2-1
2-2. Rack Mounting	2-1
2-3. Connection to the hp Transistorized Counters	2-1
2-4. Connection to hp Counters and Digital Voltmeter	2-1
2-5. Operation from Two Data Sources	2-1
2-6. Cable Fabrication	2-1
III OPERATION	3-1
3-1. Operating Controls	3-1
3-2. Paper Tape	3-1
3-3. Inked Ribbon	3-2
3-4. Taped Duplicates	3-3
3-5. Programming the Recorder	3-3
3-6. Programming the Control Board (A13)	3-3
3-7. Data Source Connections	3-4
3-8. Programming the Column Boards	3-4
3-9. Reference Voltages	3-5
3-10. Reference Voltages Adjustment	3-6
3-11. Power Supply and Internal Reference Voltages	3-6
3-12. Printing a Minus (-)	3-6
3-13. Setting the Analog Controls (optional)	3-7
3-14. Recording with Galvanometer Graphic Recorders	3-7
3-15. Using Graphic Recorders Having Different Input Sensitivities	3-8

TABLE OF CONTENTS (Cont'd)

Section	Page
IV THEORY OF OPERATION	4-1
4-1. Introduction	4-1
4-2. Control Board Operation	4-1
4-3. Column Board Operation	4-2
4-4. Analog Circuitry Operation	4-3
V TROUBLESHOOTING	5-1
5-1. Introduction	5-1
5-2. Localizing the Trouble	5-2
5-3. Semi-Conductor Replacement	5-2

Table 1-1. Specifications

Accuracy:	Identical to input device used
Printing Rate:	5 lines per second, maximum
Column Capacity:	To 11 columns (12 available on special order)
Print Wheels:	12 positions, numerals 0 through 9, a minus sign, and a blank, Other symbols available. *
Driving Source:	Parallel entry 4-line BCD, 1-2-2-4. Other codes available. Source reference voltage establishes "0" state. "0" or "1" state must not be more than 150 volts above or below ground. The binary swing should be between 4 and 75 volts.
Print Command Signal:	Positive or negative pulse, 20 μ s or greater in width, 6 to 20 volts.
Transfer Time:	Approximately 2 ms
Paper Required:	Standard 3-inch roll or folded paper
Power Requirements:	115/230 volts \pm 10%, 50/60 cps (4 prints per second maximum at 50 cps)
Dimensions:	Cabinet Mount: 20-3/4 in. wide, 12-1/2 in. high, 18-1/2 in. deep Rack Mount: 19 in. wide, 10-1/2 in. high, 16-7/8 in. deep behind panel
Weight:	Cabinet Mount: Net 35 lbs, shipping 70 lbs (approximately) Rack Mount: Net 30 lbs, shipping 63 lbs (approximately)

*See  Application Note #32 for information on special print wheels.

SECTION I
GENERAL DESCRIPTION

1-1. DESCRIPTION.

The Hewlett-Packard Model 562A Digital Recorder is a transistorized electro-mechanical device providing a printed record of digital information. Parallel data entry and low-inertia moving parts allow printing rates as high as 5 lines per second, each line containing up to 11 digits; 12 digit capacity is available on special order.

Throughout this manual the Model 562A will be referred to as the recorder.

1-2. DATA ENTRY.

Standard input for the recorder is parallel-entry 4-line BCD code, either 1224 or 1248. Input to the recorder is through rear-mounted connectors. Internal connectors route the information to any desired sequence of columns. Each column has binary storage for one decimal number.

When a print command is supplied, each storage unit assumes the condition of the decade counting unit (or other driving source) connected to it. The data transfer takes place in approximately 2 milliseconds, after which time the driving source is free to gather more information.

1-3. STANDARD INSTRUMENT.

Each storage unit is mounted on a plug-in board (column board) with a de-coding matrix. The matrix converts the stored data into positioning information for the print wheels. The recorder is supplied to translate 1224 BCD codes, but other 4-line codes are accommodated by substituting plug-in boards. Unless otherwise specified, the recorder is supplied from the factory with the following:

- a. Six +1224 column boards.
- b. Printer mechanism, 11 print wheels and associated components, five prints/second with 60 cps power line frequency.
- c. One input connector at rear of recorder J101.
- d. One input cable.
- e. One control board.
- f. One power supply board.

1-4. OPTIONS AVAILABLE.

The following options are available:

- a. + or -1224 column boards.
- b. + or -1248 column boards.
- c. Analog circuitry.
- d. Pinion gear, allows 5 prints per second with 50 cps power.
- e. Input connector (J201) and associated connectors (for dual input operation or over 9-column capacity).
- f. Data input cable.

1-5. POWER REQUIREMENTS.

The recorder has been designed to operate from 115/230 volt, 50/60 cps power. A switch, located at the rear of the recorder selects operation for either 115 or 230 volts.

The three-conductor power cable supplied with the instrument is terminated in a three-prong polarized male connector recommended by the Electrical Manufacturers' Association (NEMA). The third contact is an offset round pin, added to a standard two-blade ac plug which grounds the recorder chassis when used with the proper receptacle. An adapter should be used to connect the NEMA plug to a standard two-contact receptacle. When the adapter is used, the ground connector becomes a short green lead. The green lead should be connected to a suitable ground for protection of the operating personnel.

1-6. USES.

Because of the extreme flexibility of the recorder, it can be used with electronic counters, digital voltmeters etc. or a wide variety of individual and system applications. The recorder will operate with + or -1224, + or -1228 BCD, and 10-line code information depending on column boards installed. Two separate sources, unsynchronized, can be used to provide data if option e is installed. The recorder supplies the synchronization. When the analog circuitry, option c, is installed, the operator may select analog voltage of columns 1 through 9 in 3-column groups.

SECTION II INSTALLATION

2-1. GENERAL INFORMATION.

Section II contains information relating to installation and input connections.

2-2. RACK MOUNTING.

If the recorder is to be rack mounted, be certain to allow sufficient open space for cooling air to enter and exhaust. Do not mount the recorder next to equipment which will discharge hot air into the recorder air intake.

2-3. CONNECTION TO THE hp TRANSISTORIZED COUNTERS.

The recorder may be directly connected to the hp transistorized counters by means of the input cable supplied with the recorder. The transistorized counters have the correct connector installed. Recorder connector J101 is connected to the counter recorder connector. If a second transistorized counter is to be connected to the recorder, connection is made from the second counter to recorder connector, J201. The transistorized counter output is +1224 BCD.

2-4. CONNECTION TO hp COUNTERS AND DIGITAL VOLTMETER.

If the recorder is to be connected to the above tube type instruments a modification kit can be installed. The kit provides a +1224 BCD output.

2-5. OPERATION FROM TWO DATA SOURCES.

The recorder can be operated from two data sources, synchronized or unsynchronized, by connecting the data inputs to connectors J101 and J201. The two data inputs can be ± 1224 or ± 1248 code. The appropriate column boards must be installed in the proper connectors in the recorder.

2-6. CABLE FABRICATION.

Connection of the recorder to data sources other than the above may require construction of a cable terminated with a connector that will mate with the recorder connectors. Use small gage telephone-type wire. Number 26 gage wire meeting MIL-B-76A, with 7 strands #34 gage wire, tinned after stranding, with 105°C plastic insulation has been found satisfactory. Select a systematic color code for wires to avoid errors. Use care in soldering. Repairing faulty connections after all wires are soldered is very difficult. A length of #14 gage wire makes an excellent soldering tip for use on closely-spaced connector terminals.

SECTION III
OPERATION

3-1. OPERATING CONTROLS.

The operating controls consist of the following:

POWER ON,

supplies power to the recorder when in the ON position.

RECORD ON,

allows the printer mechanism to operate when in the ON position. When the switch is in the spring-loaded position (down), the recorder prints at maximum rate. The middle position is a standby position (allows analog to be taken).

SPACE SELECTOR,

selects the number of spaces between readout prints.

PAPER ADVANCE,

manually advances paper.

ANALOG CONTROLS,

(optional) refer to text.

3-2. PAPER TAPE.

Special ϕ folded tape is recommended for use with the recorder. High-quality standard 3-inch rolled adding machine type may also be used.

Folded tape permits convenient take-up in the paper drawer and allows easy inspection of any portion of the tape. It is perforated at each fold to allow neat separation of portions of recorded data. Folded tape may be reversed and re-run to use both sides. With single spacing, about 15,000 prints can be made on one side of a folded pad. One pad will last about 40 minutes at maximum print rate.

To install the paper tape proceed as follows:

- a. Open front panel.
- b. Load paper in compartment.
- c. Fold paper back one inch and crease. Insert paper between roller and guide plate.

d. Manually advance paper. Paper will feed easier and can be reversed with SPACE SELECTOR set to "0".

e. Feed paper under inked ribbon.

f. Feed paper through slot. Close front panel.

g. Collect printed paper in drawer.

Follow these additional instructions if roll tape is used:

a. Insert spindle through roll. Spindle is taped to bottom of paper compartment when instrument is shipped from the factory.

b. Hang roll by ends of spindle from ledges on both sides of paper compartment.

c. Paper must feed out from the bottom of the roll.

d. Continue with loading.

To feed paper rapidly use the PAPER ADVANCE thumb wheel. To manually feed paper backward, set the SPACE SELECTOR to "0" and roll the PAPER ADVANCE wheel in the reverse (up) direction. Paper feed may be reversed only with the SPACE SELECTOR set to "0".

Be sure paper is inserted squarely in the paper feed mechanism to prevent jamming. If paper does not feed smoothly, place the RECORD switch in the center position, and remove all paper from the feed mechanism. Use tweezers to pick out torn bits of paper.

3-3. INKED RIBBON.

The printer mechanism uses a special heavily-inked silk ribbon available from the Hewlett-Packard Company. Standard typewriter ribbon on an Underwood spool, with reversing rivets near the ribbon ends, may also be used; however, impressions will be lighter than with the Hewlett-Packard ribbon.

To install new ribbon, proceed as follows:

a. Open the hinged front panel to gain access to the printer mechanism.

b. Loosen the two printer mechanism retaining screws located on the lower front corners of the mechanism by turning 1/4 turn counterclockwise.

c. Slide mechanism out of cabinet until ribbon spools are readily accessible.

d. Wind all the ribbon onto one spool.

- e. Shift the two ribbon spool retaining springs away from the spools, and remove spools.
- f. Take the ribbon out of the mechanism. Save the empty spool.
- g. Hook end of new ribbon on empty spool. Wind about 10 inches of ribbon on the spool so that the reversing rivet is on the spool.
- h. Install new ribbon by feeding it over the ribbon rollers and between the print wheels and paper tape.
- i. Feed ribbon through the slots in the reversing arms and around the lower guides. Ribbon must be twisted 90° between the ribbon roller and the slot in the reversing arm.
- j. Place ribbon spools on their shafts. Fasten spools in place with the spool retaining springs. Ribbon must feed out from the bottom of each spool.
- k. Replace printer mechanism in cabinet and tighten retaining screws.

3-4. TAPE DUPLICATES.

Transparent paper, *hp* stock no. 9251-0052 is recommended for use in the recorder. This paper produces much less paper dust and copies can be easily made with duplication machines. If duplicate tape records are required from standard paper, contact print duplicating methods, such as the ozalid process, can be used by printing directly from the original tape records.

3-5. PROGRAMMING THE RECORDER.

The recorder can be programmed to accept different codes if the proper column boards are installed. The column boards may be inter-mixed if desired.

The standard recorder is supplied with six +1224 BCD column boards, with connectors installed to accept a total of nine column boards. If more than nine column operation is desired, J201 must be installed with the connectors that attach to the rear of the column boards (P110-P115).

Normally J101 supplies data to column boards A1-A9, but connectors P101-P109 can be connected to supply data to any of the column boards the operator desires. J201 can supply data to any of the remaining column boards. Connectors P110-P115 can be connected to supply data to six column boards.

3-6. PROGRAMMING THE CONTROL BOARD (A13).

Connectors P201 and P202 supply control signals to the data sources, and return data source signals to the control board. Connector P201 is con-

nected to one data source through J101, and P202 to a second data source through J201. The control board senses when commands from both sources have been received, then starts the printing cycle. If only one data source is used, the control board connector that is not being used must be disconnected, otherwise the recorder will not operate but will wait until the control board receives a second print command signal. When the control board connector that is not being used is disconnected, the associated print command binary remains in the proper state of unbalance. Thus a print command is required from only one data source to start the printing cycle.

3-7. DATA SOURCE CONNECTIONS.

Data can be supplied continuously from two data sources. If six column readout is desired for one data source and five column readout is desired for the second data source, then one data source is connected to J101 and the other data source to J201. The column board connectors can be connected as the operator desires. Other combinations the operator may want can be had by changing the connectors at the rear of the column boards.

3-8. PROGRAMMING THE COLUMN BOARDS.

The following tables are for 1224 and 1248 BCD code.

Table 3-1. 1224 Column Board

Character to be Printed	Binary Input			
	D	C	B	A
	Weight			
	4	2	2	1
0	0	0	0	0
1	0	0	0	1
2	0	0	1	0
3	0	0	1	1
4	0	1	1	0
5	0	1	1	1
6	1	1	0	0
7	1	1	0	1
8	1	1	1	0
9	1	1	1	1
-	1	0	0	1
blank	1	0	0	0

Table 3-2. 1248 Column Board

Character to be Printed	Binary Input			
	D	C	B	A
	Weight			
	8	4	2	1
0	0	0	0	0
1	0	0	0	1
2	0	0	1	0
3	0	0	1	1
4	0	1	0	0
5	0	1	0	1
6	0	1	1	0
7	0	1	1	1
8	1	0	0	0
9	1	0	0	1
-	1	0	1	1
blank	1	0	1	0

The following notes refer to tables 3-1 and 3-2:

1 and 0 definitions

- 1) 1 indicates "1" level binary input.
- 2) 0 indicates "0" level binary input.

"1" and "0" levels (BCD input)

- 1) In a +1224 code, the "1" level is positive with respect to the "0" level.
- 2) In a -1224 code, the "1" level is negative with respect to the "0" level.
The + or - prefix is determined by the polarity of the "1" level with respect to the "0" level.

3-9. REFERENCE VOLTAGES.

Input to the binaries is through gates which are controlled by two dc-biasing signals which control the passage of transfer pulses. One of the biasing signals is the BCD data input and the other is a reference voltage. The transfer pulses are internally-generated within the recorder. The inputs to the binaries are capacitively-coupled and may be floating with respect to chassis ground. The reference voltage is thus required to establish a point to which the BCD signal is referred. Two reference voltages are required in the data storage system and should generally be the steady dc values of the 0 and 1 states of the BCD input signal. This relationship of reference to BCD signal is shown in figure 3-1 for a negative-going signal equal to the 1 level.

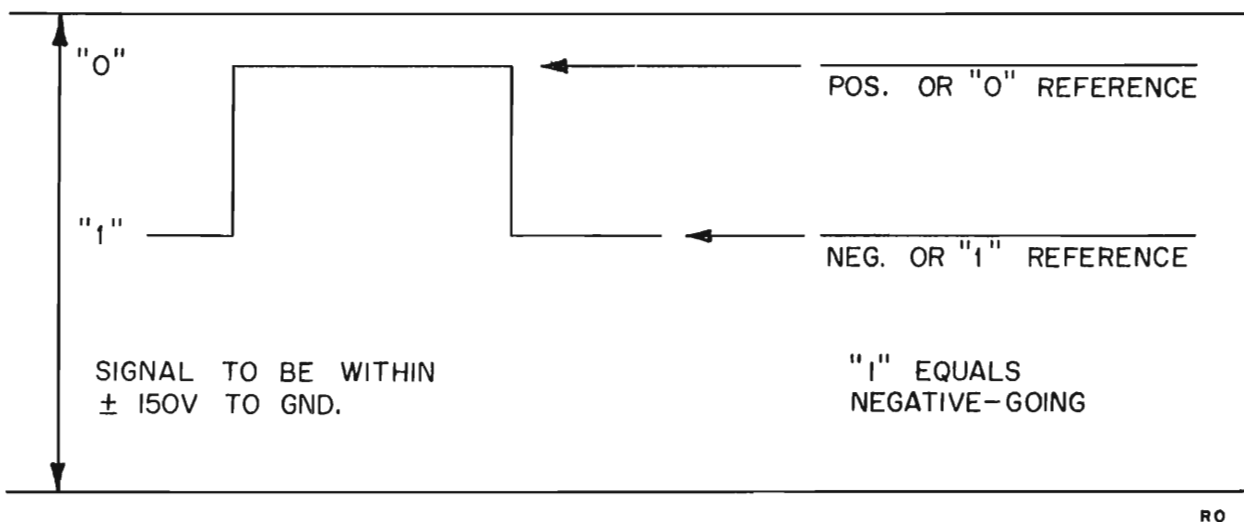

Figure 3-1. Reference Levels.

3-10. REFERENCE VOLTAGE ADJUSTMENT.

The input voltage applied for any column board must not exceed 150 volts. That is the reference voltage plus the BCD "1" level should not be greater than 150 volts. For instance, if the BCD swing is from 100 volts ("0" level) to 160 volts ("1" level) then attenuation must be introduced to reduce the "0" level to 94 volts and the "1" level to 150 volts. The minus reference voltage can then be adjusted for 94 volts. The plus reference level must then be adjusted to 150 volts.

Before a reference voltage can be chosen, the "0" and "1" levels of the equipment supplying the BCD signals must be known. For instance if the recorder is connected to a binary counter with a -1248 code, each column board will be driven by a decade in the counter. Sometimes binaries in the decades have different "1" and "0" levels, thus a proper reference voltage must be chosen. If the column board is a -1248 code, then the -reference voltage must be chosen that includes the "1" levels applied to the A, B, C, and D binaries. A +reference voltage must be chosen that will include the "0" levels for the A, B, C, and D binaries.

If high impedance reference levels are used (above 5000 ohms), suitable by-passing, providing a time constant of 150 μ s, should be used. If the BCD drive is derived from an unregulated supply, then it is desirable to obtain the reference voltage from the same unregulated supply.

3-11. POWER SUPPLY AND INTERNAL REFERENCE VOLTAGES.

The power supply board, A16, supplies the dc voltages required by the recorder. The power supply also has provisions for providing reference voltages of -9 to +17 volts. The operator can select a value of resistors or breakdown diodes needed to provide the proper reference voltages. Connectors P301 and P302 (optional) supply the reference voltages to the column boards. When using an external reference voltage, connectors P301 and P302 must be disconnected from the power supply board if resistors are installed. Unless specified by the customer, resistors are not installed. The proper mounting holes are in the power supply board and the operator can install the resistors or breakdown diodes required to give the desired voltage.

3-12. PRINTING A MINUS (-).

The recorder will normally print a blank with no BCD input. If the operator wishes to print a -(minus) for a 1224 code, in place of a blank, proceed as follows: In table 3-1 under the column headed "character to be printed", find -(minus). Under the "Binary Input" column, the - character must have a "1" input for the A and D binaries. If the column board is a +1224 code, then the external voltage applied to the A binary input must be at least 4 volts more positive than the negative reference voltage. Since the D binary has a "1" supplied

by the transfer pulse when the "0" level is not present, no external voltage is required for the D binary. A -1224 code requires the same voltages but of different polarity.

If the column board is a +1248 code, in table 3-2 find -(minus). Under the "Binary Input" column, the - character must have a "1" input for the A, B, and D binaries. An external voltage applied to the A binary must be at least 4 volts more positive than the negative reference voltage. The B and D binaries do not require an external voltage as the transfer pulse supplies the "1" level when "0" level is not present. A -1248 code requires the same external voltages, but of different polarity.

3-13. SETTING THE ANALOG CONTROLS (optional).

The POTENTIOMETER RECORDER binding posts on the 562A are designed to operate potentiometer type (voltage operated) recorders having 100-millivolt-full-scale sensitivity, and greater than 50K ohm input resistance. The 562A can also drive recorders having other values of input sensitivity and resistance by making minor additions or modification to the POTENTIOMETER RECORDER ANALOG OUTPUT.

To use the 562A on a potentiometer recorder, proceed as follows:

- a. Set the COLUMN SELECTOR to include the three number columns to be recorded graphically.
- b. Connect the potentiometer recorder to the POTENTIOMETER RECORDER binding posts on the 562A.
- c. Set the OPERATE lever switch to the GALV. ZERO position (the GALV. ZERO control has no effect on the POTENTIOMETER RECORDER output) but does supply zero output at potentiometer jack.
- d. Zero set the potentiometer recorder with its own controls.
- e. Set the OPERATE lever switch to the CALIBRATE position.
- f. Adjust the CALIBRATE control to obtain full-scale deflection of the recorder pen.
- g. Repeat steps c, d, e, and f.
- h. Set the OPERATE lever switch to OPERATE. The graphic recorder will now plot the number columns indicated by the COLUMN SELECTOR.

3-14. RECORDING WITH GALVANOMETER GRAPHIC RECORDERS.

The GALVANOMETER RECORDER output jack on the 562A is designed to operate galvanometer type (current operated) recorders having 1-milliampere-

full-scale sensitivity and less than 5000 ohms input resistance. The 562A can also drive recorders having other values of input sensitivity and resistance by making minor additions or modifications to the GALVANOMETER RECORDER ANALOG OUTPUT.

To use the 562A with a galvanometer recorder, proceed as follows:

- a. Before connecting the recorder to the 562A, determine which three of the number columns are to be plotted. Then set the COLUMN SELECTOR to include these three number columns.
- b. Zero set the galvanometer recorder with its own controls.
- c. Connect the recorder to the GALVANOMETER RECORDER jack using a standard, 1/4-inch diameter three-circuit phone plug. The positive recorder terminal is connected to the ring contact on the plug, and the negative terminal to the tip on the plug.
- d. Set the OPERATE lever switch to the GALV. ZERO position.
- e. If necessary, zero set the recorder with the GALV. ZERO set control on the 562A.
- f. Set the OPERATE lever switch to the CALIBRATE position.
- g. Adjust the CALIBRATE control to obtain full-scale deflection of the recorder pen.
- h. Set the OPERATE lever switch to the OPERATE position. The recorder will now plot the number columns indicated by the COLUMN SELECTOR.

3-15. USING GRAPHIC RECORDERS HAVING DIFFERENT INPUT SENSITIVITIES.

To use a potentiometer recorder having greater than specified voltage sensitivity, shunt the recorder with a value of resistance which results in full-scale deflection of the recorder pen while the 562A is set to CALIBRATE and the CALIBRATE control is centered.

Potentiometer recorders having less than 50K ohm input resistance may be used, but the POTENTIOMETER RECORDER output will than provide less than 100 millivolts for full-scale deflection. The internal resistance at the POTENTIOMETER RECORDER output is approximately 2500 ohms and when loaded with this value, provides only 50 millivolts for full scale deflection. If the potentiometer recorder has sufficient sensitivity to operate with the lower input level, no modification is required to use the recorder. However, as the external resistance on the POTENTIOMETER RECORDER binding posts is decreased, so is the range of the CALIBRATE control, until at some low resistance it may be necessary to provide an external calibrating control

consisting of a potentiometer connected as a variable shunt for the signal which is fed to the graphic recorder.

If a potentiometer or galvanometer recorder is to be used which requires slightly greater output voltage or current, it is possible to increase the 562A ANALOG OUTPUT by changing the values of certain resistors in the analog circuits.

SECTION IV

THEORY OF OPERATION

4-1. INTRODUCTION.

Operation of the 562A is dependent upon a series of timing and reference voltages. The timing voltages are supplied by the control board (A13). Reference voltages can be supplied by the power supply (A14) or by an external source. The following paragraphs will describe the functions of various circuits in the recorder.

4-2. CONTROL BOARD OPERATION.

Operation of the recorder is dependent upon a series of timing voltages developed by the control board. Refer to the functional diagram, figure 5-2. Assume the data source initiates a print command. Print Command Binary Number 1 changes state and immediately supplies the data source with a disable voltage. Assume Print Command Binary Number 2 has its input connector arranged so only one print is required. The Print Scan Schmitt is in the proper state because the shutter is open. The Print Scan Schmitt applies the proper signal to the "And" Gate. The "And" Gate conducts and causes the Clutch Binary to change state. The clutch solenoid starts to energize. When the Clutch Binary changes state, a signal is applied to the Delay Multivibrator (2MS). The output of the 2 ms delay multivibrator produces a reset pulse which is applied to the storage binaries. This removes stored information and sets the storage binaries in the proper state to receive new information. The output of the 2 ms delay multivibrator is also applied to a 60 μ s delay multivibrator. The output of the 60 μ s multivibrator is applied to the storage binary gate diodes by way of the + and - Transfer Amplifiers, then data transfer takes place. The output of the 60 μ s multivibrator is also applied to the Print Command Binaries and resets them. While this action is occurring, the clutch solenoid is completing its pull-in cycle. When the clutch solenoid has engaged the clutch, the clutch will remain engaged for one complete revolution of the clutch assembly because of mechanical action. As the clutch assembly rotates, the shutter closes, de-energizing the photo conductor. This causes the schmitt to change state, initiating the scan signal. The scan signal then resets the clutch binary and opens the Inhibit Gate circuits which can allow the pawl magnets to energize. When the brush senses the correct voltage, the pawl magnets de-energize and lock the print wheels at the proper position. Then the character is printed as the clutch assembly finishes its one revolution, disengages, and opens the shutter. The photo conductor is energized and the system is ready for the next print command.

4-3. COLUMN BOARD OPERATION.

The following theory is for operation of a -1248 code column board. Assume a data source has initiated a print command, the AND GATE in the control board conducts, and the clutch solenoid starts to energize. A signal is then applied to the 2 MS DELAY MULTIVIBRATOR by the clutch binary. After 2 ms, the multivibrator applies a positive reset pulse to the column boards. The binaries reset as follows:

A BINARY: Q101, on; Q102, off

B BINARY: Q103, off; Q104, on

C BINARY: Q105, on; Q106, off

D BINARY: Q107, off; Q108, on

The data source is supplying bcd information to the four binaries. Suppose the bcd information supplied is for the decimal number 8. According to table 3-1, "0" level information will be supplied to the C, B, and A binaries. The D binary will have "1" level information supplied. The "0" or "1" do not change the state of the binaries. The - and + transfer pulses cause the binaries to change state if the "0" or "1" levels needed are present. At the D binary, if the "1" level is present CR104 is forward biased and - transfer pulse will go through diode gate CR104. Since Q107 is off, the D binary will change state, Q107 on and Q108 off.

The C binary has "0" level information applied to diode gate CR103. A + transfer pulse is applied to CR103. Since the "0" level information applied to CR103 is equal to the + reference voltage, the diode will pass the + transfer pulse. Thus Q105 is off and Q106 is on.

The B binary has "0" level information applied to diode gate CR102. Since the "0" level information is (at least 4 volts) more positive than the -reference voltage, diode CR102 is reverse biased and will not pass the - transfer pulse. The binary will not change state. Transistor Q103 remains off and Q104 remains on.

The A binary has "0" level information applied to diode gate CR101. The "0" level must be equal to the positive reference voltage. This causes CR101 to be forward biased and pass the + transfer pulse. The A binary changes state, Q101 off and Q102 on.

Three of the halves of the binaries that are "on" will return, through matrix resistors, to pin 11 of connectors XA1-1 to XA12-1. This is the line which corresponds to the decimal number 8. In this case, R161, R175, and R199 return to the line for the decimal number 8. These resistors make the line for the number 8 go to approximately +15 volts. Diode gate CR105 and CR106 sense when the line gets to approximately +15 volts and cause amplifiers Q109, Q110, and Q111 to de-energize the pawl magnet. The pawl then locks the

print wheel at that position. The number is then printed. When the data source initiates another print command, the scan signal occurs a short time later and causes amplifiers Q109, Q110, and Q111 to energize the pawl magnet if the data input has changed. The print wheel rotates. The magnet remains energized until diode CR105 has +15 volts applied from the matrix.

4-4. ANALOG CIRCUITRY OPERATION.

Since the column boards contain stored binary information, an analog function can be derived to drive a strip chart recorder. The analog circuitry provides the following:

- a. A graphic presentation whereby the trend of recorded data can be seen at a glance.
- b. Three digits of analog information where full scale on the recorder may be a few parts per million of the original printed reading.
- c. A recording where an increasing numerical count is always an upward direction on the strip chart recording.
- d. An analog recording which is always on scale.

To derive the analog voltage a switching arrangement is used which utilizes the stored binary data from three consecutive columns of the printed data. Any three of the first nine columns may be used as well as the first two right hand digits.

The binary output data is weighted according to the code required by the storage units. Four resistors are used to develop a staircase function from the four storage binaries. The four weighting resistors are in the ratio 4221. Refer to the analog circuitry schematic. Each of the three storage decades then produces a staircase function with a level proportional to the numerical value of its stored binary data.

The three staircase voltages are then mixed in proportion to their decade value or in the ratio of 1, 10, 100, to produce a single staircase function 1000 part in amplitude. Each discrete step then represents .1% of full scale and for practical purposes is an analog function. This output voltage is then attenuated and applied directly to a potentiometer type strip chart recorder.

The analog signal is also applied to an amplifier whose output can be used to drive a 1 ma type galvanometer recorder.

Diode clamps insure accurate voltage levels before mixing. Compensation elements maintain constant output over wide temperature extremes.

SECTION V
TROUBLESHOOTING

5-1. INTRODUCTION.

Section V contains information relating to symptom, trouble, and localization of troubles which may occur in the recorder. Table 5-1 lists the symptom, then a possible cause. It must be remembered that troubles other than those listed could cause a malfunction. The table lists the most possible cause.

Table 5-1. Troubleshooting

Symptom	Possible Cause
No printer action when only one data source is used	See that the unused connector at the rear of the control board (A13) is disconnected. Make sure print command is proper polarity.
No printer action when two data sources are used	Check power supply voltages, check print command binaries, check if both data sources are initiating print commands and of proper polarity.
All columns print incorrect character	Check power supply voltages, check the control board for proper reset, transfer, and scan signals (listed in timing voltage table). Make sure reference voltages are correct.
One particular column prints an incorrect character	Check the column board associated with the particular print wheel. Interchange column boards, if operation is restored, trouble is in column board. Make sure reference voltages to column board are correct.
Printer mechanism will not operate	Press the RECORD ON switch to the down position. Recorder should print at maximum rate. If not, check fuses and power supply.
Incorrect analog voltage	Make sure recorder is zeroed. Check +11 volt power supply on analog board. Check clamp diodes.

5-2. LOCALIZING THE TROUBLE.

When a trouble has been traced to a specific board, make voltage measurements on base, emitter, and collector of transistors. On the column board binaries, transistors that are "turned on" will have approximately +15 volts on the collector, transistors that are "turned off" will have approximately -5 volts on the collectors. Binary tables 5-2 to 5-5 list the states of the column board binary transistors for various numbers and inputs. Binaries in the control board can be checked for switching action with a dc coupled oscilloscope. When a binary changes state, the dc coupled oscilloscope will show a definite change of dc level. A vacuum tube voltmeter can be used also. Figure 5-1 shows the timing voltages and sequence. Resistance measurements made between various sockets and connectors may be helpful. For this, use the wiring and power supply diagram.

5-3. SEMI-CONDUCTOR REPLACEMENT.

Table 5-3 lists the various transistors and diodes. When a commercial replacement type is not listed, the semi-conductor should be ordered from the Hewlett Packard Company. When two  stock numbers are listed, the second number is the correct replacement.

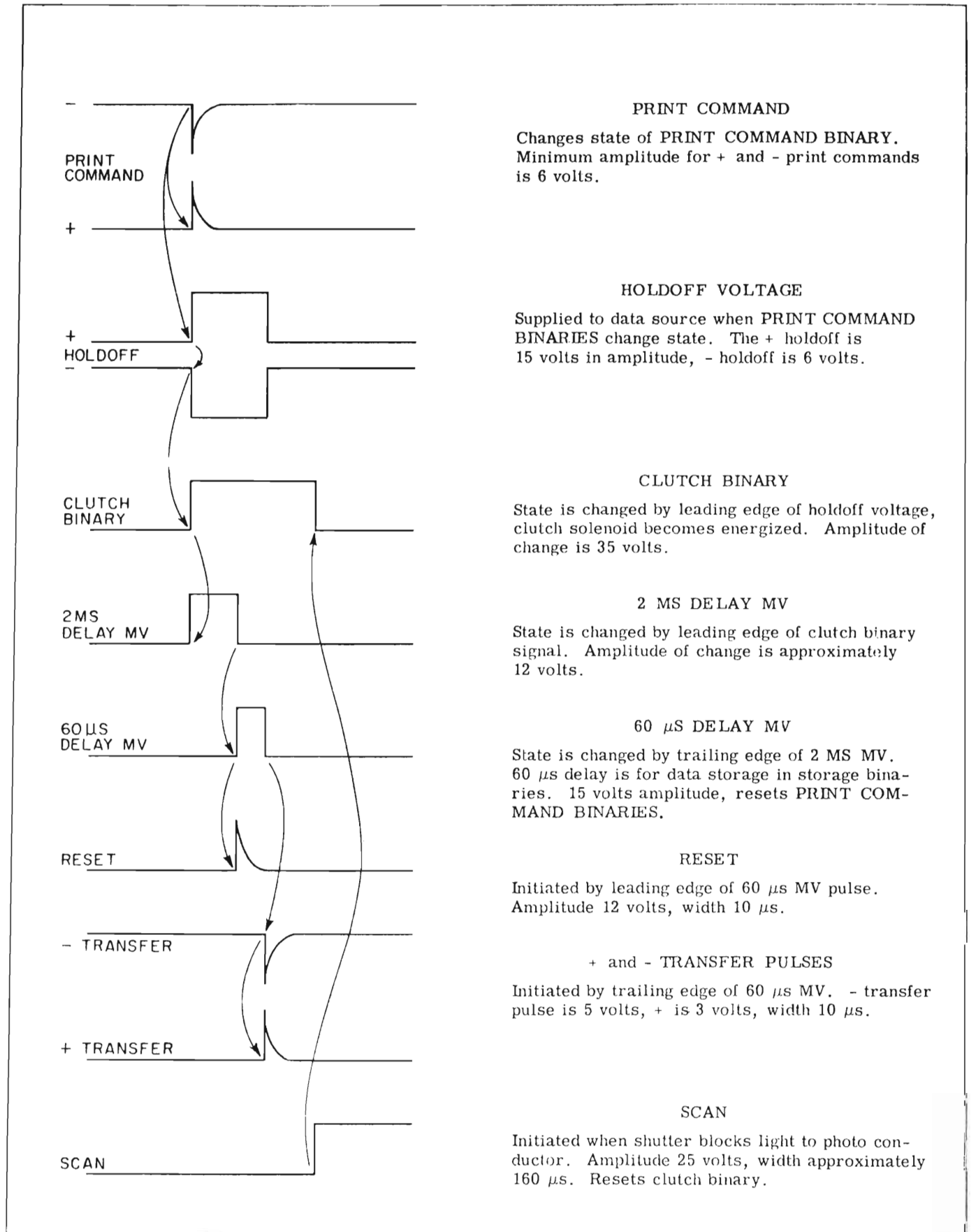

Figure 5-1. Timing Voltages

Table 5-2. -1248 Code

-	8		4		2		1					
Character	D BINARY		C BINARY		B BINARY		A BINARY					
	BCD INPUT		BCD INPUT		BCD INPUT		BCD INPUT					
	Q107	Q108	Q105	Q106	Q103	Q104	Q101	Q102				
1	0	off	on	0	off	on	0	off	on	1	on	off
3	0	off	on	0	off	on	1	on	off	1	on	off
5	0	off	on	1	on	off	0	off	on	1	on	off
7	0	off	on	1	on	off	1	on	off	1	on	off
9	1	on	off	0	off	on	0	off	on	1	on	off
-	1	on	off	0	off	on	1	on	off	1	on	off
Blank	1	on	off	0	off	on	1	on	off	0	off	on
8	1	on	off	0	off	on	0	off	on	0	off	on
6	0	off	on	1	on	off	1	on	off	0	off	on
4	0	off	on	1	on	off	0	off	on	0	off	on
2	0	off	on	0	off	on	1	on	off	0	off	on
0	0	off	on	0	off	on	0	off	on	0	off	on

BCD INPUT: "0" is zero level input, "1" is one level input

Table 5-3. +1248 Code

+	8		4		2		1					
Character	D BINARY		C BINARY		B BINARY		A BINARY					
	BCD INPUT		BCD INPUT		BCD INPUT		BCD INPUT					
	Q107	Q108	Q105	Q106	Q103	Q104	Q101	Q102				
1	0	on	off	0	on	off	0	on	off	1	off	on
3	0	on	off	0	on	off	1	off	on	1	off	on
5	0	on	off	1	off	on	0	on	off	1	off	on
7	0	on	off	1	off	on	1	off	on	1	off	on
9	1	off	on	0	on	off	0	on	off	1	off	on
-	1	off	on	0	on	off	1	off	on	1	off	on
Blank	1	off	on	0	on	off	1	off	on	0	on	off
8	1	off	on	0	on	off	0	on	off	0	on	off
6	0	on	off	1	off	on	1	off	on	0	on	off
4	0	on	off	1	off	on	0	on	off	0	on	off
2	0	on	off	0	on	off	1	off	on	0	on	off
0	0	on	off	0	on	off	0	on	off	0	on	off

BCD INPUT: "0" is zero level input; "1" is one level input

Table 5-4. -1224 Code

-	4			2			2			1		
Character	D BINARY			C BINARY			B BINARY			A BINARY		
	BCD INPUT			BCD INPUT			BCD INPUT			BCD INPUT		
		Q107	Q108		Q105	Q106		Q103	Q104		Q101	Q102
1	0	off	on	0	off	on	0	off	on	1	on	off
3	0	off	on	0	off	on	1	on	off	1	on	off
5	0	off	on	1	on	off	1	on	off	1	on	off
7	1	on	off	1	on	off	0	off	on	1	on	off
9	1	on	off	1	on	off	1	on	off	1	on	off
-	1	on	off	0	off	on	0	off	on	1	on	off
Blank	1	on	off	0	off	on	0	off	on	0	off	on
8	1	on	off	1	on	off	1	on	off	0	off	on
6	1	on	off	1	on	off	0	off	on	0	off	on
4	0	off	on	1	on	off	1	on	off	0	off	on
2	0	off	on	0	off	on	1	on	off	0	off	on
0	0	off	on	0	off	on	0	off	on	0	off	on

BCD INPUT: "0" is zero level input; "1" is one level input

Table 5-5. +1224 Code

+	4			2			2			1		
Character	D BINARY			C BINARY			B BINARY			A BINARY		
	BCD INPUT			BCD INPUT			BCD INPUT			BCD INPUT		
		Q107	Q108		Q105	Q106		Q103	Q104		Q101	Q102
1	0	on	off	0	on	off	0	off	on	1	off	on
3	0	on	off	0	on	off	1	on	off	1	off	on
5	0	on	off	1	off	on	1	on	off	1	off	on
7	1	off	on	1	off	on	0	off	on	1	off	on
9	1	off	on	1	off	on	1	on	off	1	off	on
-	1	off	on	0	on	off	0	off	on	1	off	on
Blank	1	off	on	0	on	off	0	off	on	0	on	off
8	1	off	on	1	off	on	1	on	off	0	on	off
6	1	off	on	1	off	on	0	off	on	0	on	off
4	0	on	off	1	off	on	1	on	off	0	on	off
2	0	on	off	0	on	off	1	on	off	0	on	off
0	0	on	off	0	on	off	0	off	on	0	on	off

BCD INPUT: "0" is zero level input; "1" is one level input

Table 5-6. Semi-Conductor Replacement

Assembly	Component	Ⓢ Stock No.	Commercial Replacement
A1-A12	Q101-Q110 Q111 CR101-CR106	1850-0033 or 1850-0062 1901-0024	Philco 2N598 2N1183B
A13	Q201-206 Q207 Q208 Q209 Q210-Q214, 216 Q215 CR201, 202, 204, 205, 217-220 CR203, 206-210 CR216	1850-0033 or 1850-0062 1850-0033 or 1850-0062 1901-0024 G11A	Philco 2N598 2N1672 2N1304 2N1373 Philco 2N598 2N1672 Silicon Diode
A16	CR301-305 CR306 CR307 CR308	 G-31G-10H G-31G-7L G-31G-27L	1N2069 or 1N3293
A14	Q401, 403, 405-407 Q402, 404 CR401-416 421, 425, 426 CR423, 424 CR420 CR422	1854-0003 G11A G-29A-29 1902-0017 1902-0022	2N1304
Power Supply	Q1, Q2		2N1136 or 2N301

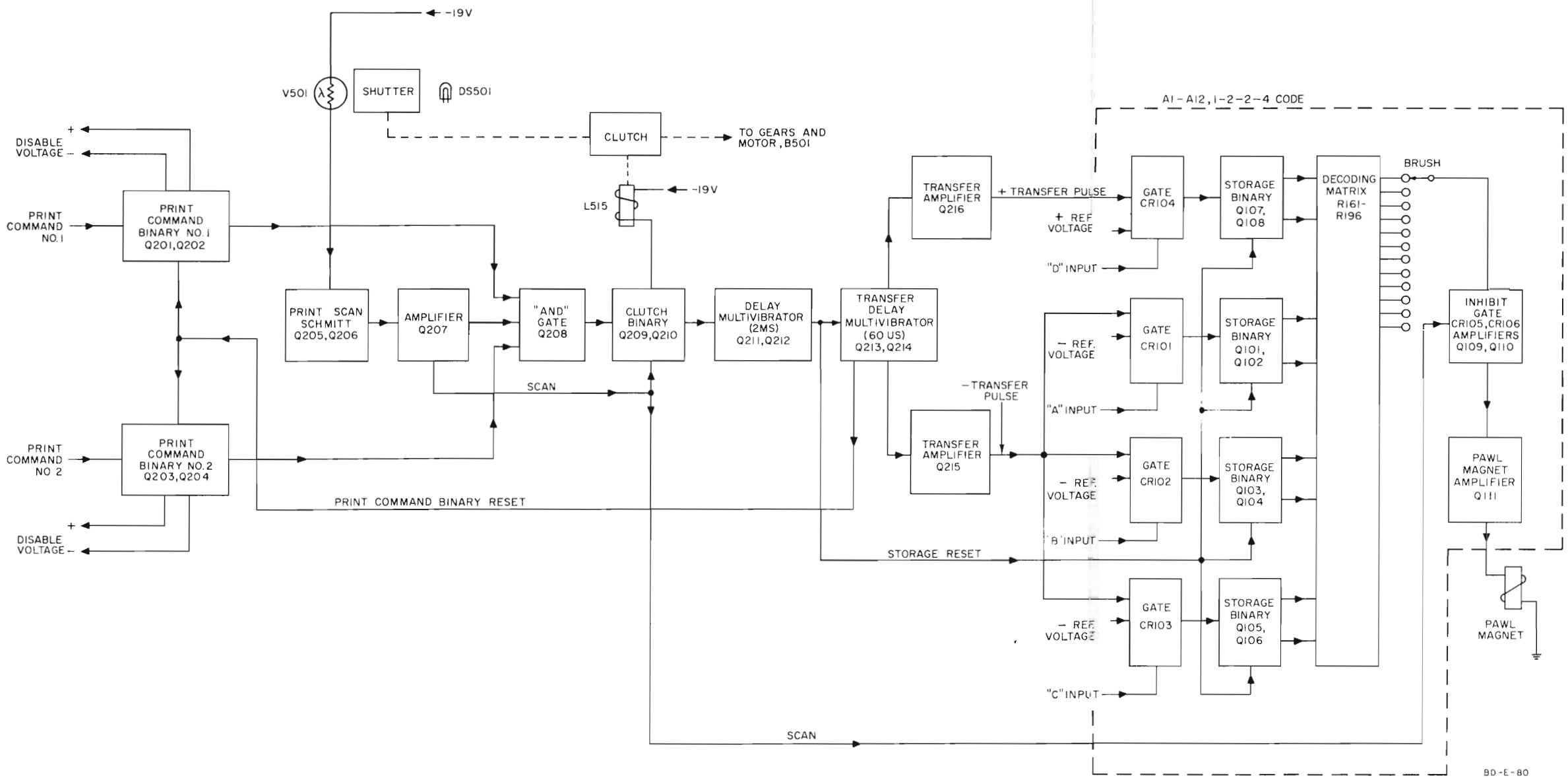

80-E-80

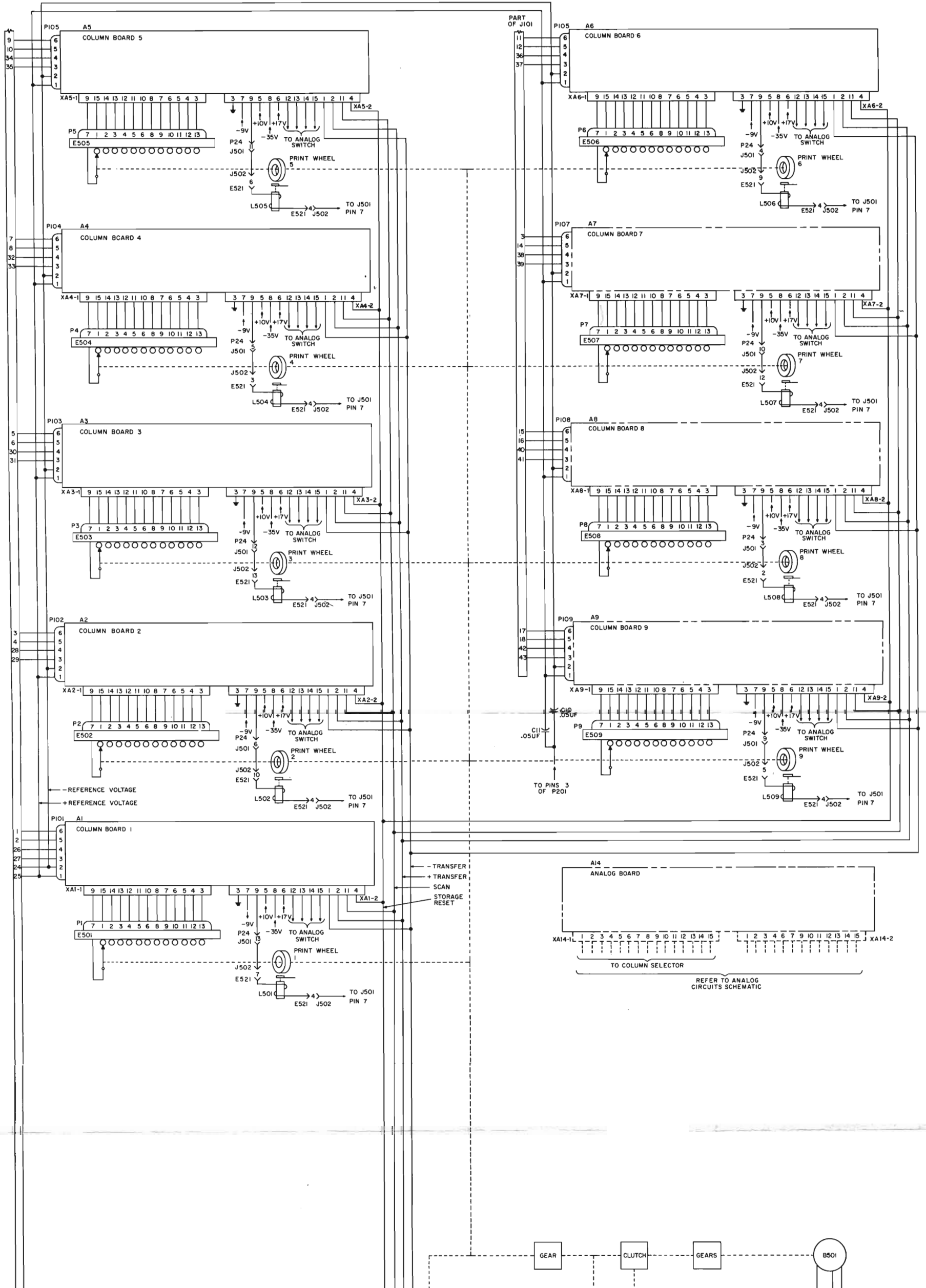
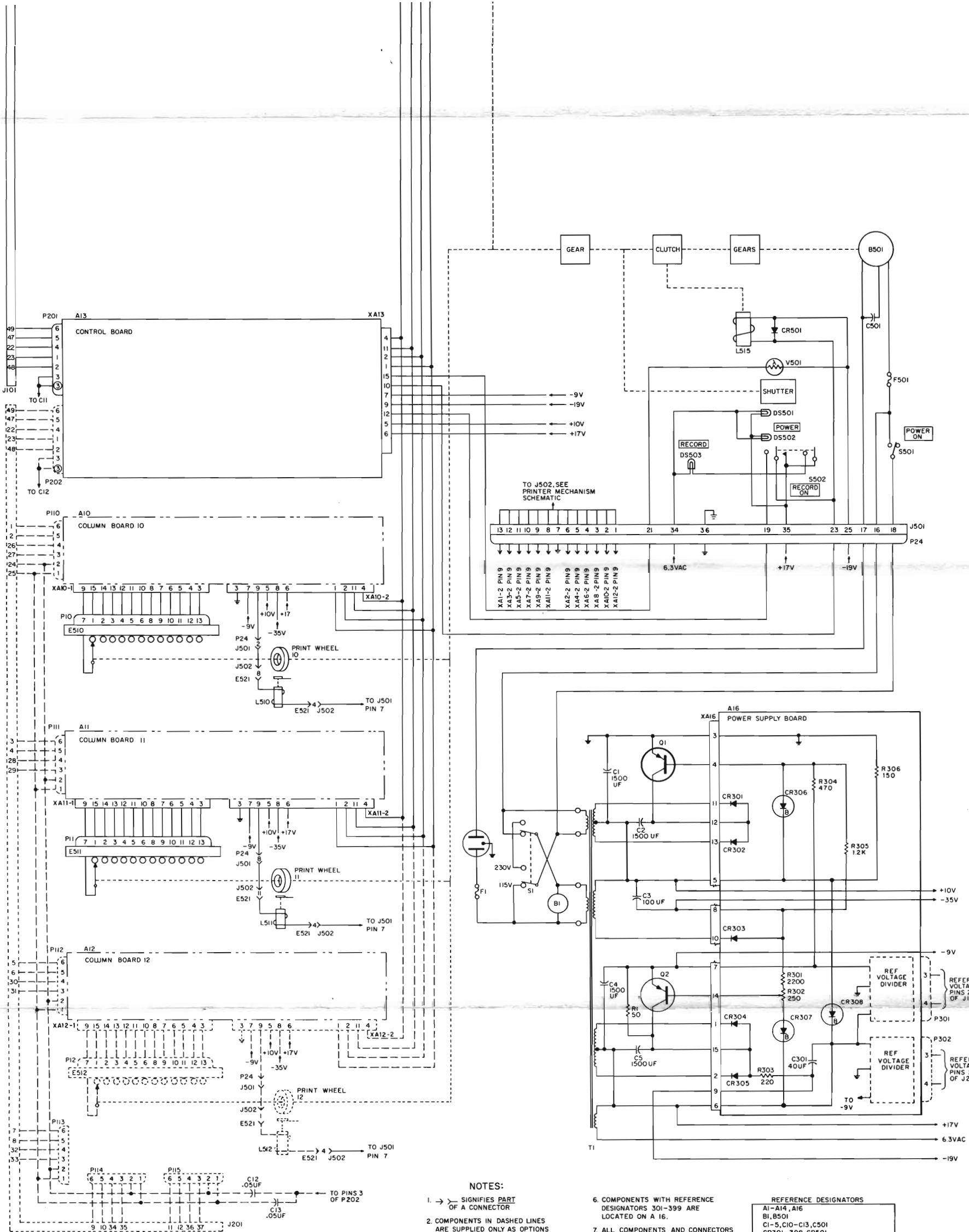

Figure 5-3



COPYRIGHT 1961 BY HEWLETT-PACKARD COMPANY
 This drawing is intended for the operation and maintenance of Hewlett-Packard equipment and is not to be used otherwise or reproduced without written consent of the Hewlett-Packard Company. 562A - WIRING & P.S. - T-121c

NOTES:

1. → SIGNIFIES PART OF A CONNECTOR
2. COMPONENTS IN DASHED LINES ARE SUPPLIED ONLY AS OPTIONS OR WITH SPECIAL INSTRUMENTS.
3. COMPONENTS WITH REFERENCE DESIGNATORS FROM 1-99 ARE LOCATED ON THE MAIN CHASSIS.
4. COMPONENTS WITH REFERENCE DESIGNATORS 101-199 ARE LOCATED ON A1-A12. CONNECTORS WITH REFERENCE DESIGNATORS 101-199 ARE SUPPLIED WITH STANDARD INSTRUMENT EXCEPT FOR P201. (SUPPLIED WITH STD. INSTRUMENT).
5. COMPONENTS WITH REFERENCE DESIGNATORS 201-299 ARE LOCATED ON A13. CONNECTORS WITH REFERENCE DESIGNATORS 110-115 ARE SUPPLIED ONLY AS OPTIONS OR WITH SPECIAL INSTRUMENTS.
6. COMPONENTS WITH REFERENCE DESIGNATORS 301-399 ARE LOCATED ON A 16.
7. ALL COMPONENTS AND CONNECTORS WITH REFERENCE DESIGNATORS 501-599 ARE LOCATED ON THE PRINTER MECHANISM, IF NOT SHOWN WITH DASHED LINES.
8. COMPONENTS WITH REFERENCE DESIGNATORS 401-499 ARE LOCATED ON A14

REFERENCE DESIGNATORS	
A1-A14, A16	AI-A14, A16
BI, B501	BI, B501
C1-5, C10-C13, C501	C1-5, C10-C13, C501
CR301-308, CR501	CR301-308, CR501
DS501, 502, 503	DS501, 502, 503
E501-512, E521	E501-512, E521
F1, F501	F1, F501
J101, J201, J501, J502	J101, J201, J501, J502
L501-512, L515	L501-512, L515
P1-P12, P24, P101-P115, P201, P202	P1-P12, P24, P101-P115, P201, P202
Q1, Q2	Q1, Q2
SI, S501, S502	SI, S501, S502
T1	T1
V501	V501

Section V
 Figure 5-3

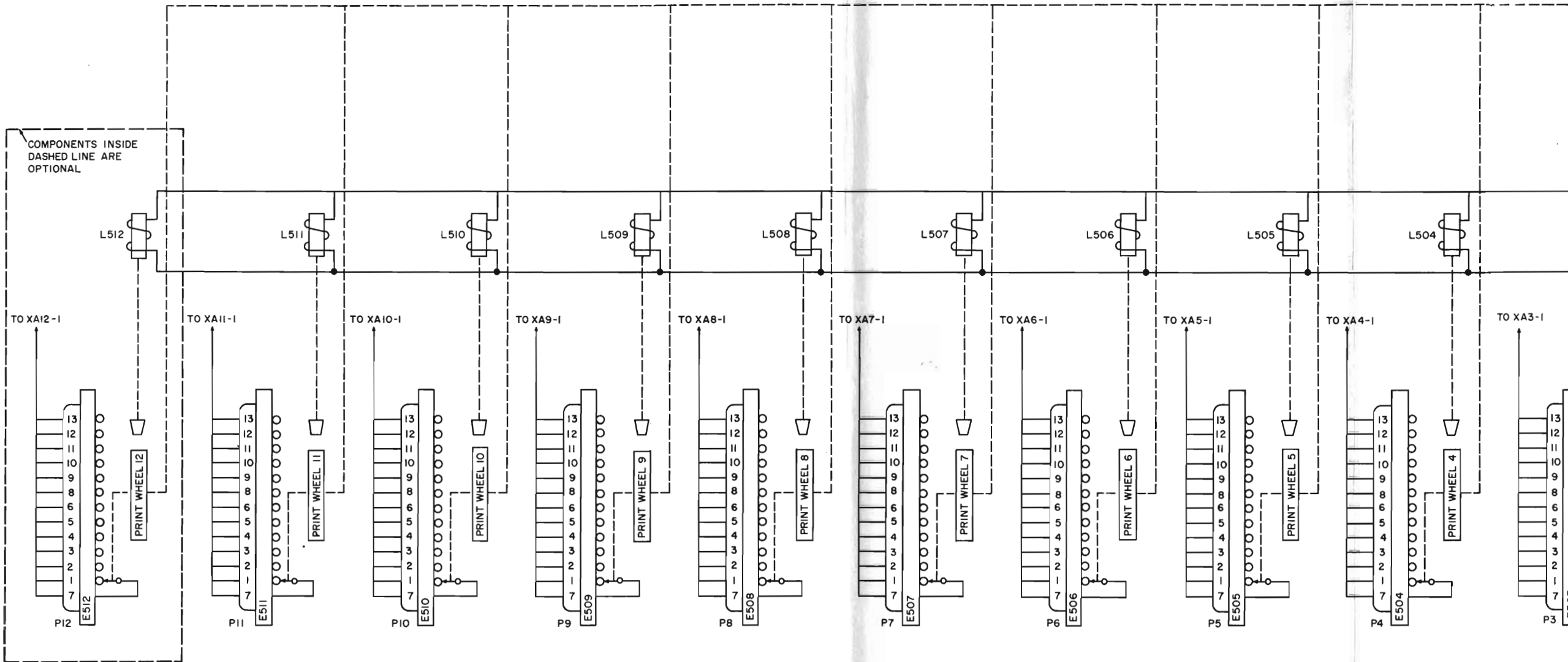

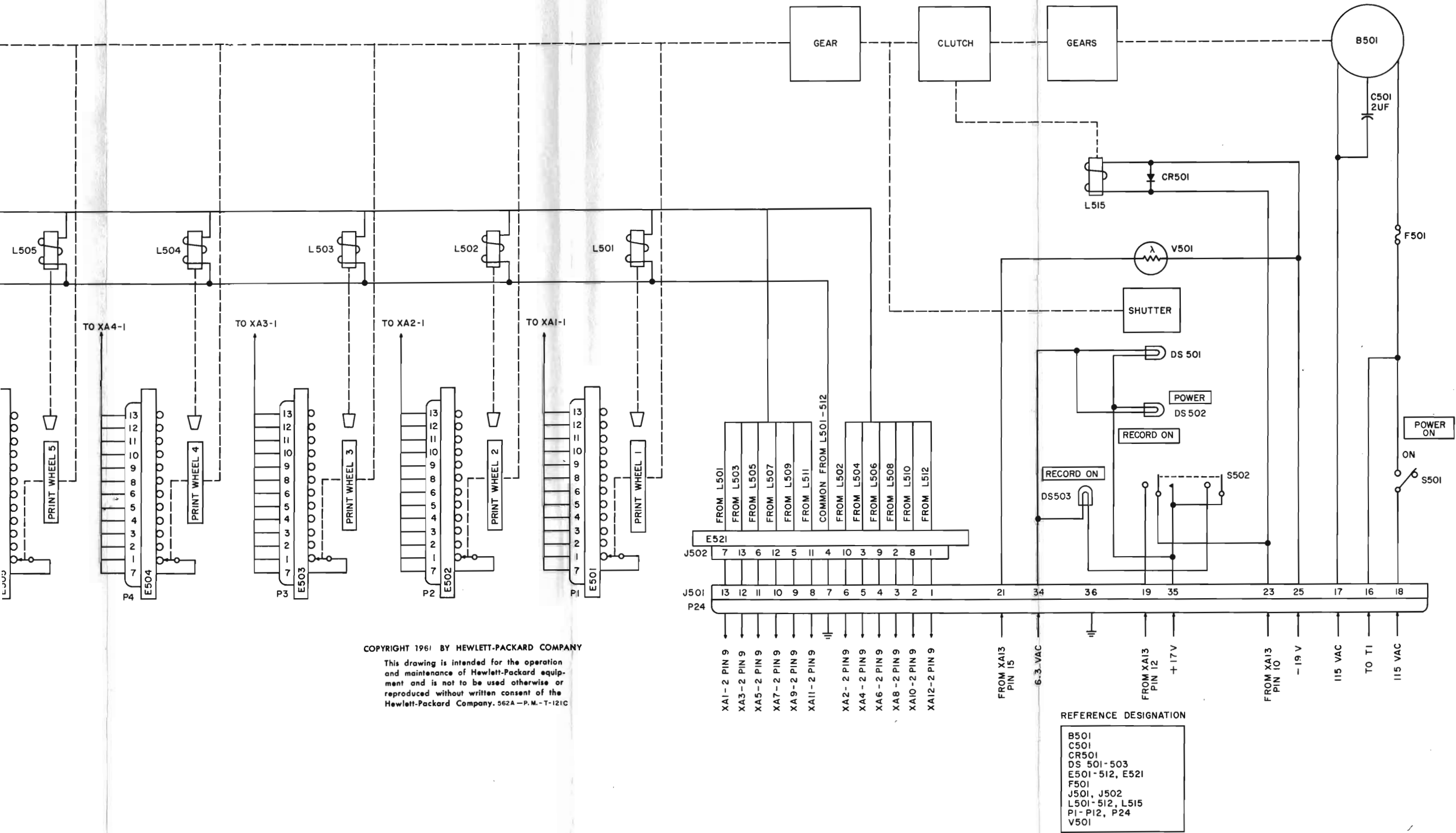
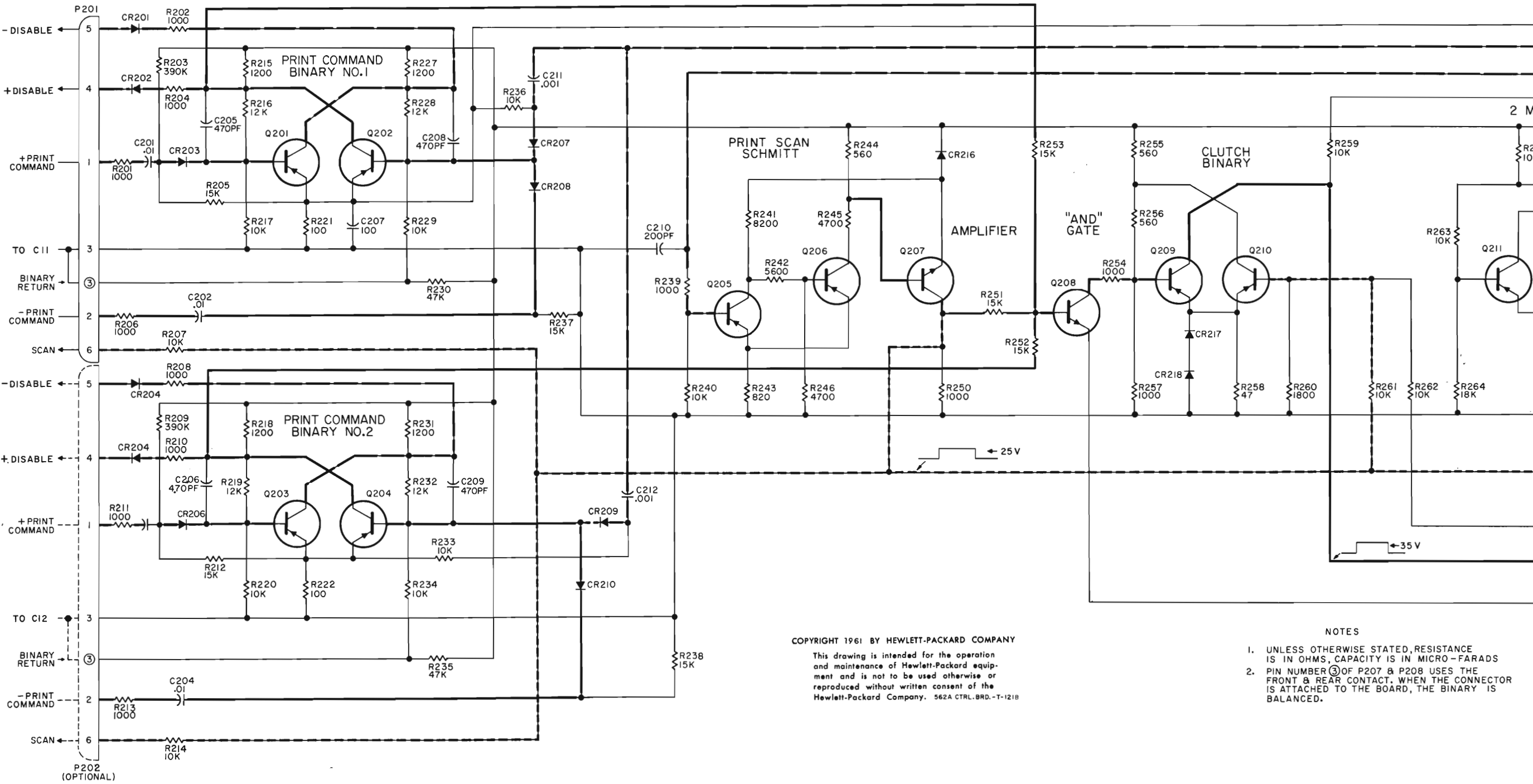
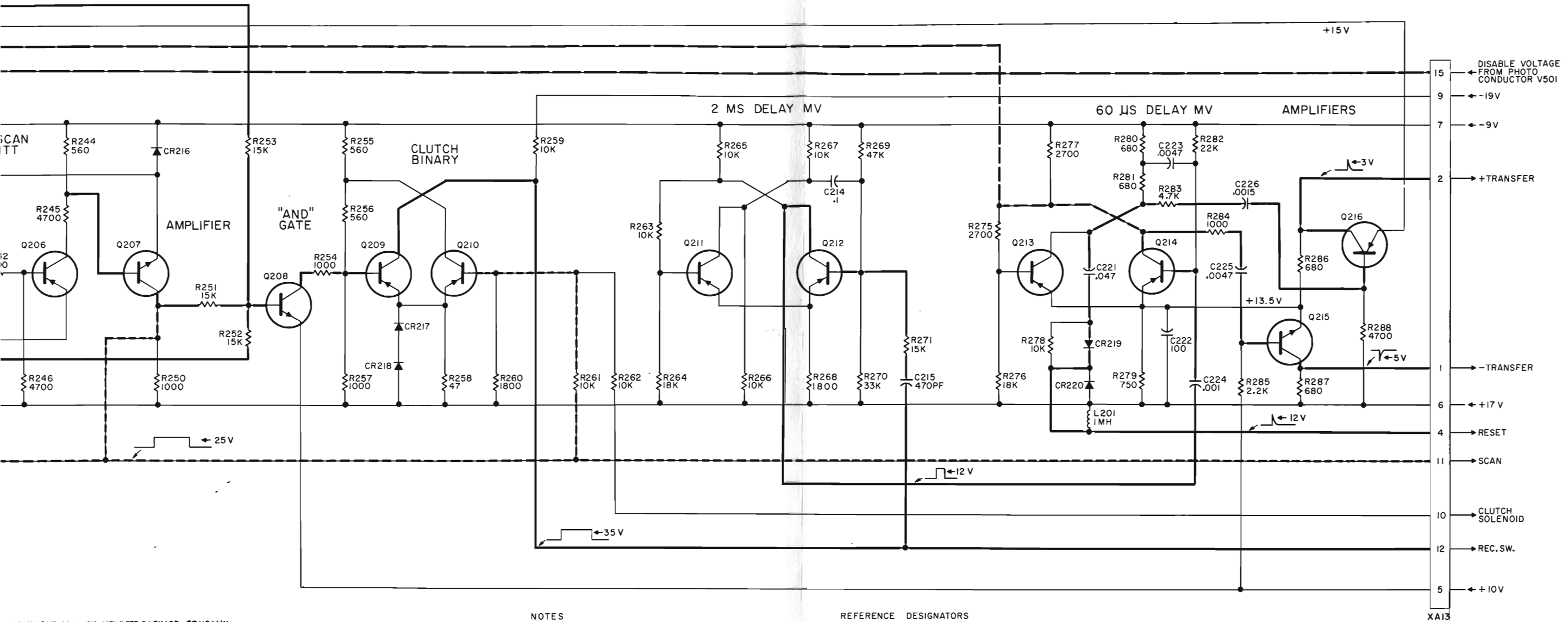

Figure 5-4
Printer Mechanism



COPYRIGHT 1961 BY HEWLETT-PACKARD COMPANY
 This drawing is intended for the operation and maintenance of Hewlett-Packard equipment and is not to be used otherwise or reproduced without written consent of the Hewlett-Packard Company. 562A CTRL. BRD.-T-121B

- NOTES
1. UNLESS OTHERWISE STATED, RESISTANCE IS IN OHMS, CAPACITY IS IN MICRO-FARADS
 2. PIN NUMBER ③ OF P207 & P208 USES THE FRONT & REAR CONTACT. WHEN THE CONNECTOR IS ATTACHED TO THE BOARD, THE BINARY IS BALANCED.



COPYRIGHT 1961 BY HEWLETT-PACKARD COMPANY

This drawing is intended for the operation and maintenance of Hewlett-Packard equipment and is not to be used otherwise or reproduced without written consent of the Hewlett-Packard Company. 562A CTRL. BRD.-T-121B

NOTES

1. UNLESS OTHERWISE STATED, RESISTANCE IS IN OHMS, CAPACITY IS IN MICRO-FARADS
2. PIN NUMBER ③ OF P207 & P208 USES THE FRONT & REAR CONTACT. WHEN THE CONNECTOR IS ATTACHED TO THE BOARD, THE BINARY IS BALANCED.

REFERENCE DESIGNATORS

C201-212, C214, 215, 221-226
CR201-210, 216-220
L201
P207-208
J13
Q201-216
R201-222, 227-246, 250-271, 275-288

Figure 5-5
Control Board

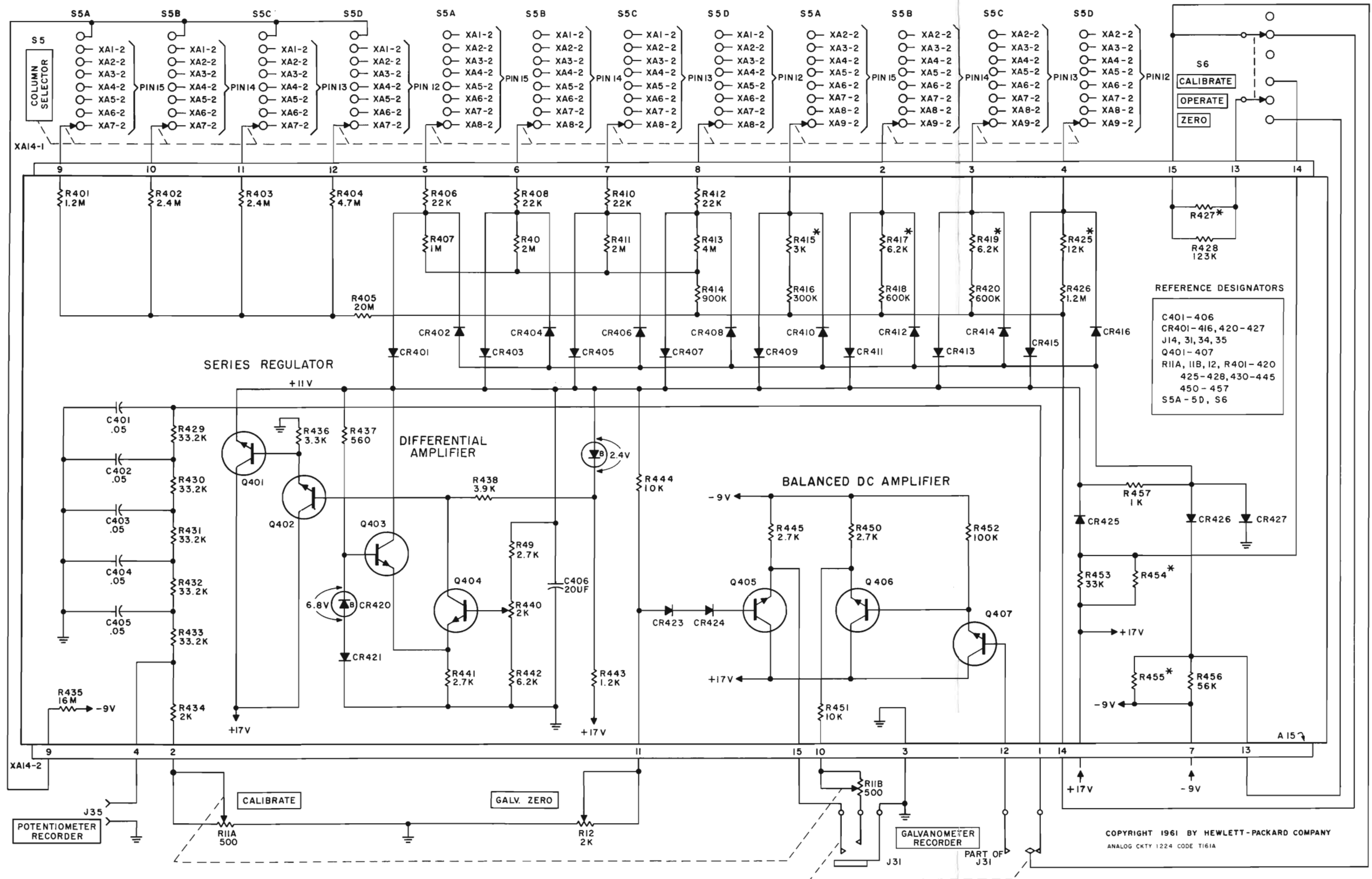

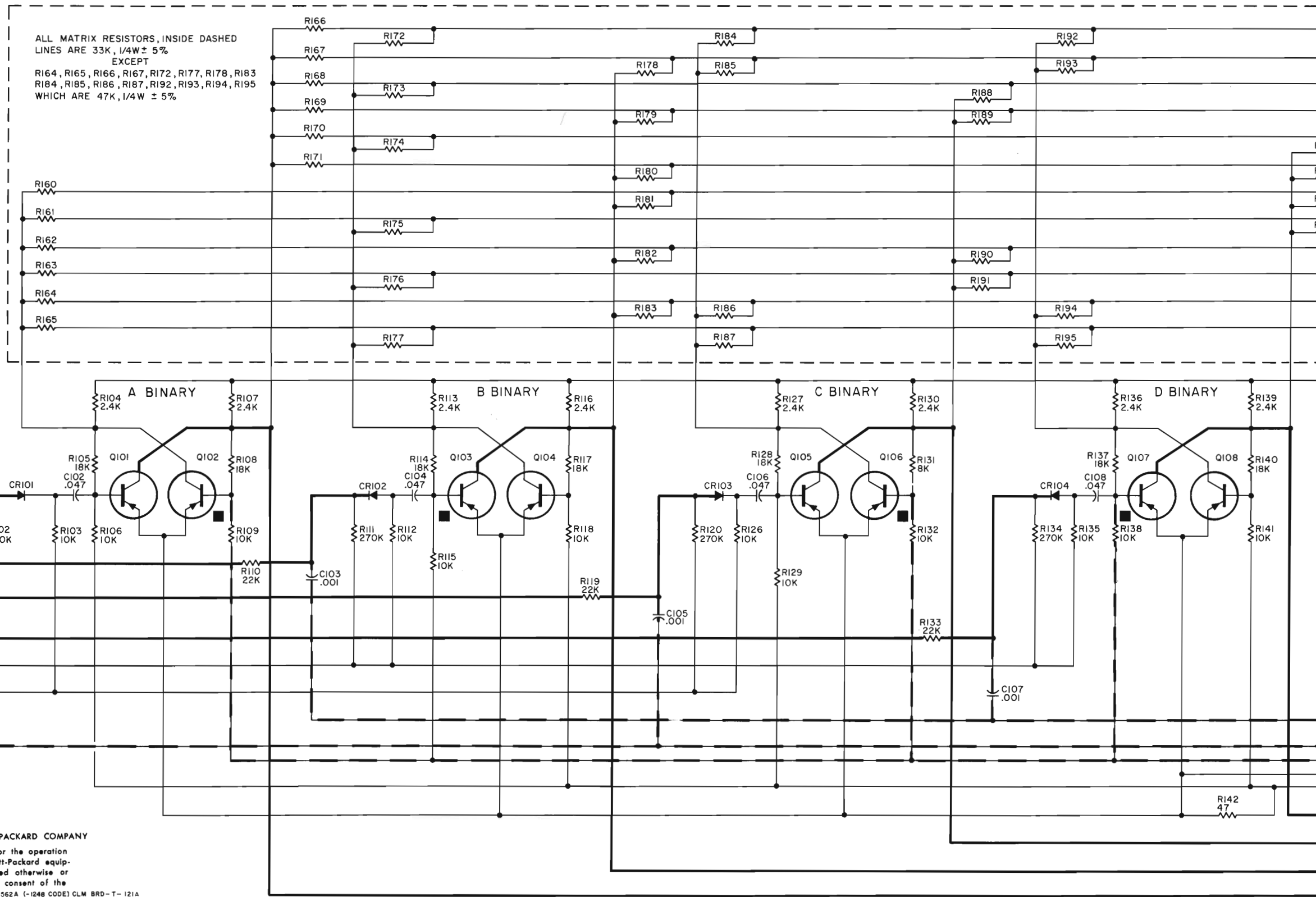

COPYRIGHT 1961 BY HEWLETT-PACKARD COMPANY
 This drawing is intended for the operation and maintenance of Hewlett-Packard equipment and is not to be used otherwise or reproduced without written consent of the Hewlett-Packard Company. 562A (-1248 CODE) CLM BRD-T-121A

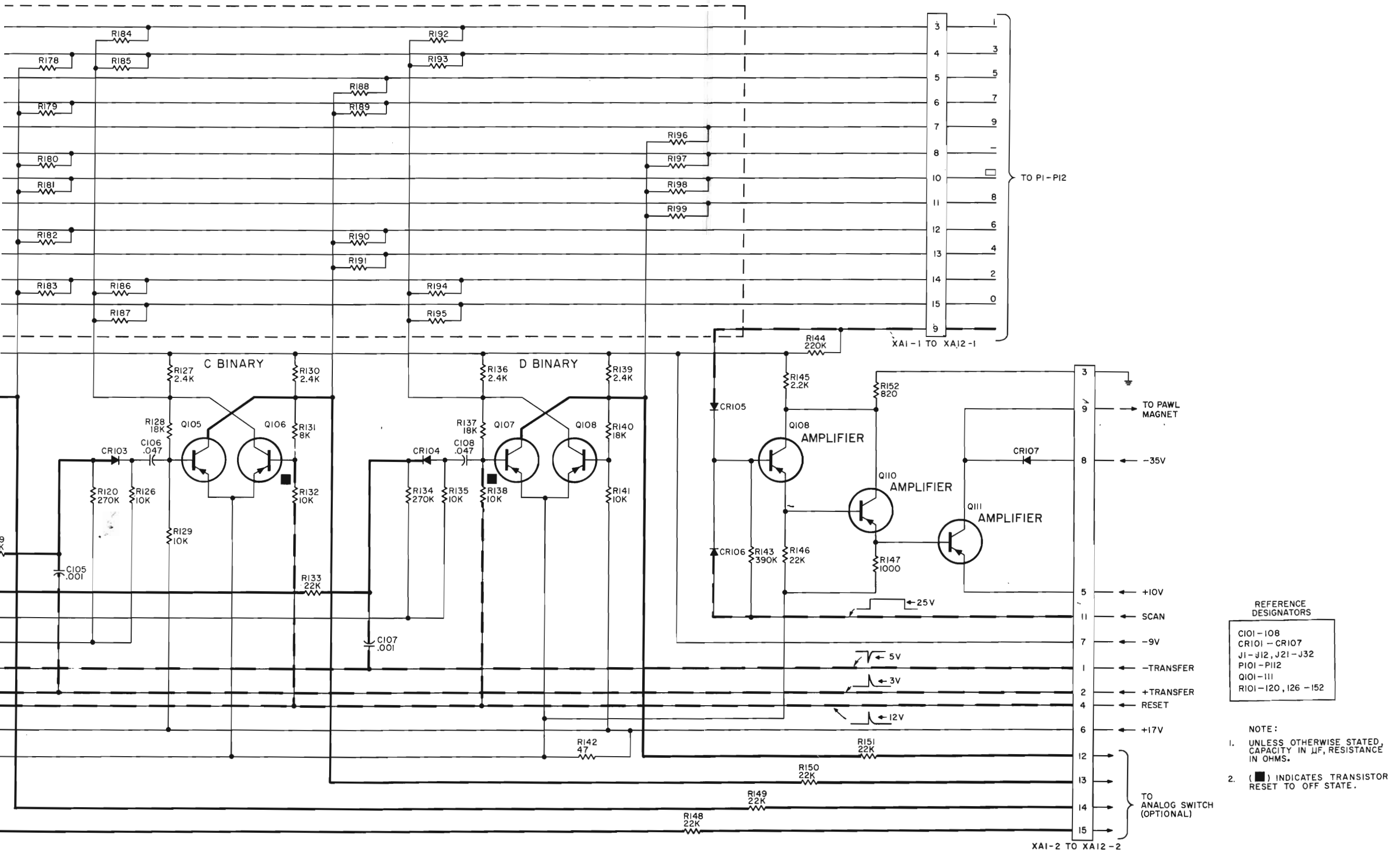
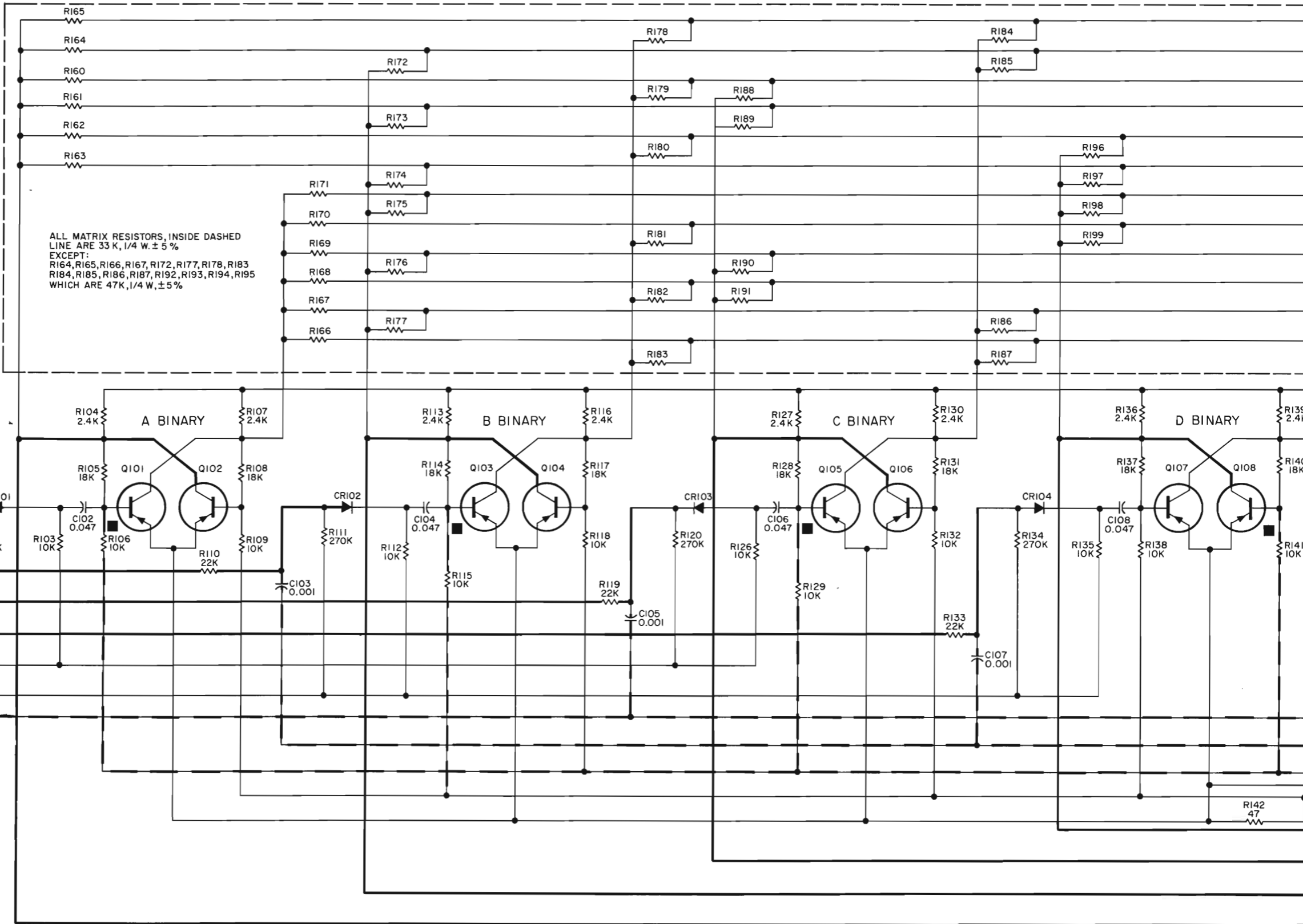
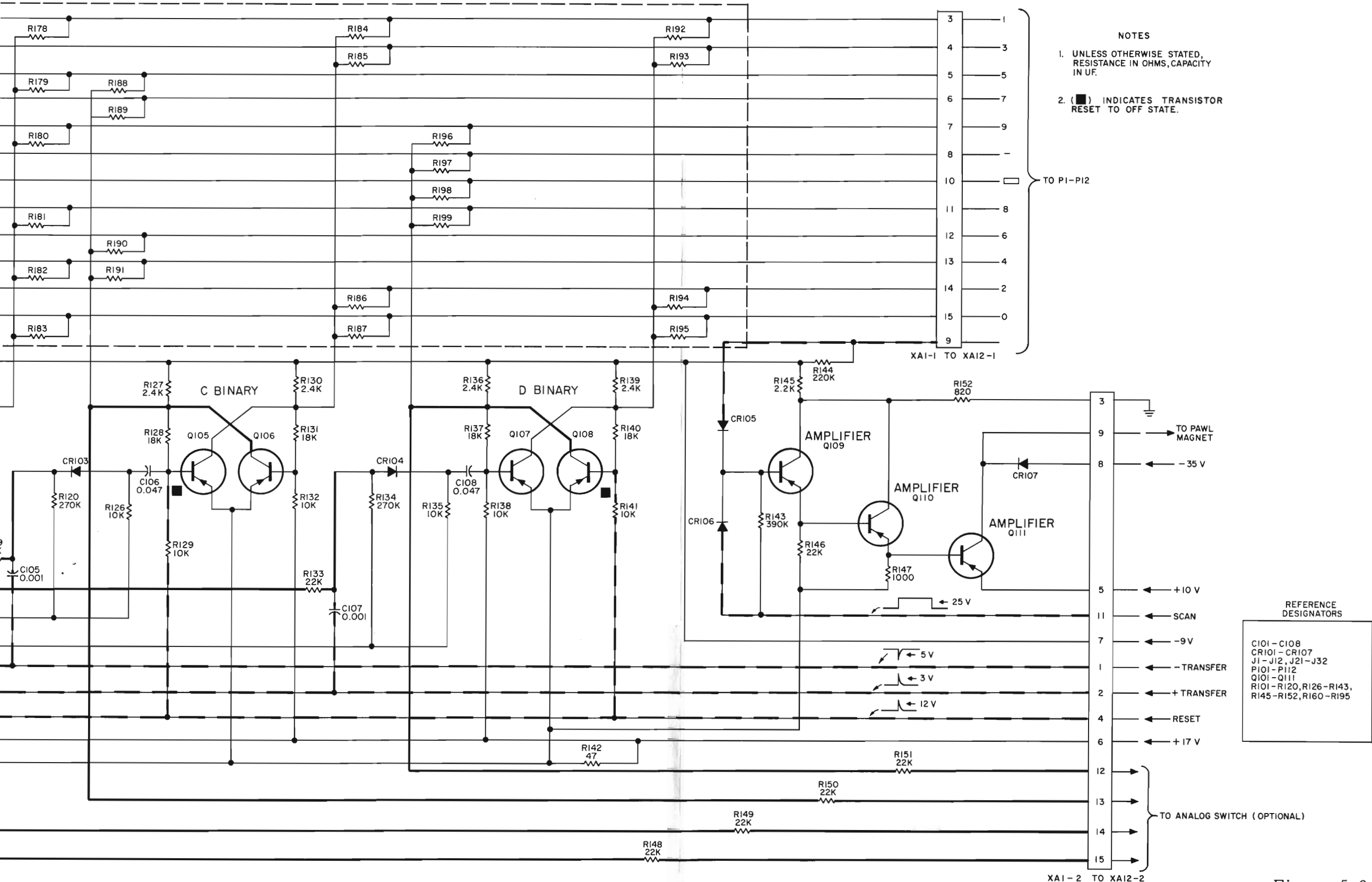

Figure 5-7
-1248 Code Column Board



ALL MATRIX RESISTORS, INSIDE DASHED LINE ARE 33 K, 1/4 W, ± 5 %
EXCEPT:
R164, R165, R166, R167, R172, R177, R178, R183
R184, R185, R186, R187, R192, R193, R194, R195
WHICH ARE 47K, 1/4 W, ± 5 %

COPYRIGHT 1961 BY HEWLETT-PACKARD COMPANY
This drawing is intended for the operation and maintenance of Hewlett-Packard equipment and is not to be used otherwise or reproduced without written consent of the Hewlett-Packard Company.
562A, +1248 CODE CLM BRD T121A



- NOTES
1. UNLESS OTHERWISE STATED, RESISTANCE IN OHMS, CAPACITY IN UF.
 2. (■) INDICATES TRANSISTOR RESET TO OFF STATE.

REFERENCE DESIGNATORS

C101 - C108
 CR101 - CR107
 J1 - J12, J21 - J32
 P101 - P112
 Q101 - Q111
 R101 - R120, R126 - R143,
 R145 - R152, R160 - R195

Figure 5-8
+1248 Code Column Board

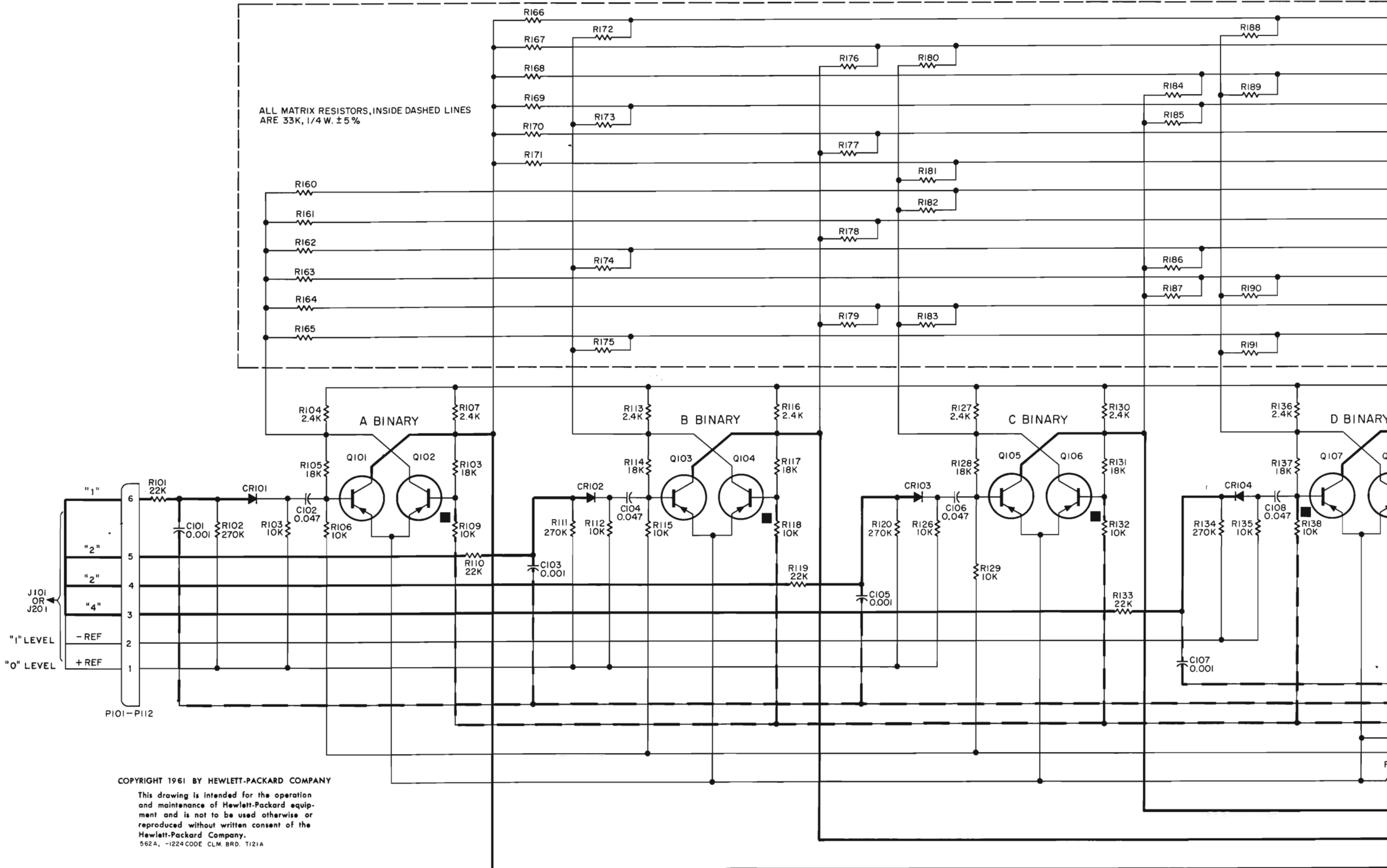

ALL MATRIX RESISTORS, INSIDE DASHED LINES ARE 33K, 1/4 W. ±5%

COPYRIGHT 1961 BY HEWLETT-PACKARD COMPANY

This drawing is intended for the operation and maintenance of Hewlett-Packard equipment and is not to be used otherwise or reproduced without written consent of the Hewlett-Packard Company.
562A, -1224 CODE CLM. BRD. T121A

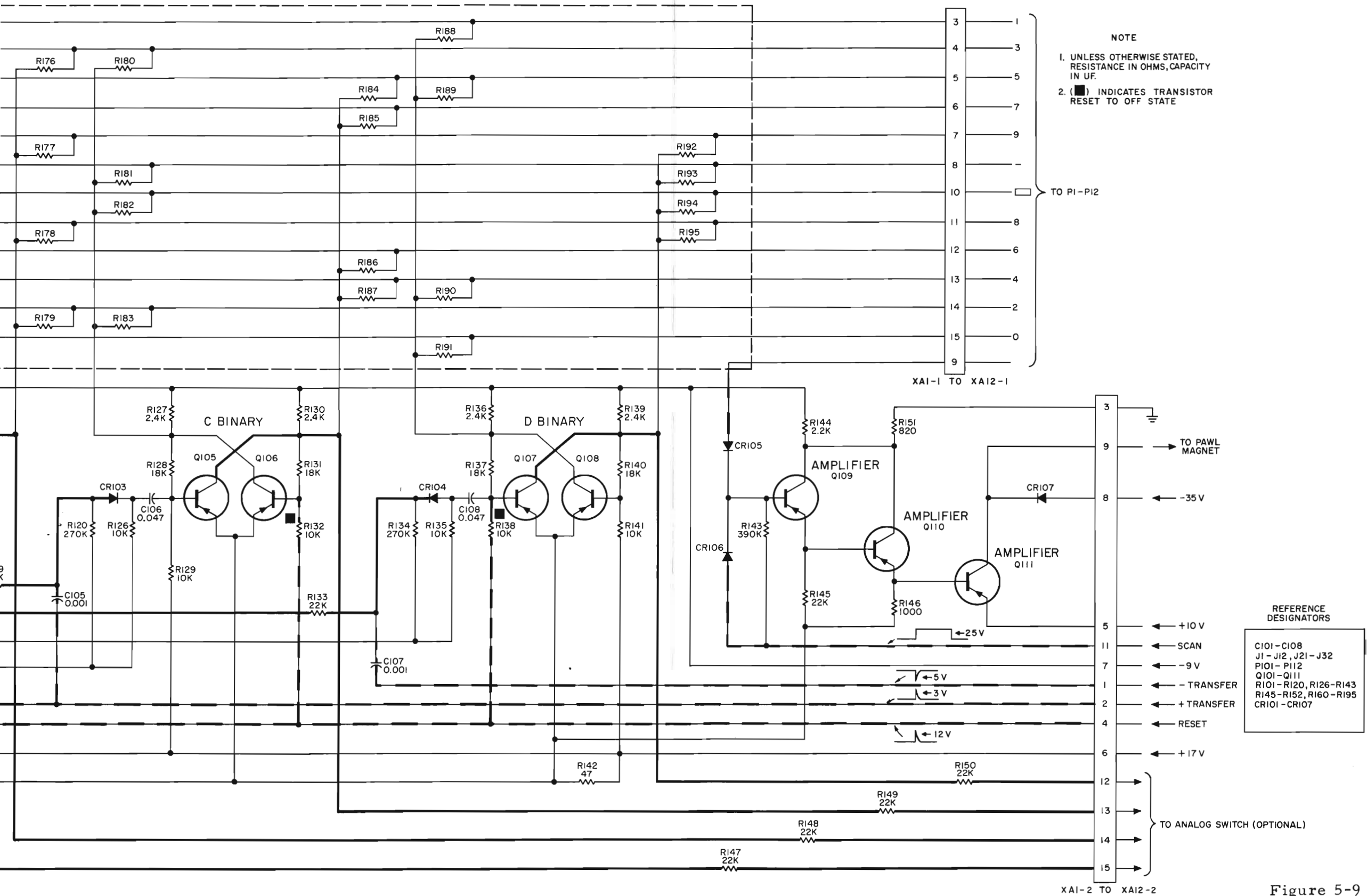

XA1-2 TO XA12-2

Figure 5-9
-1224 Code Column Board

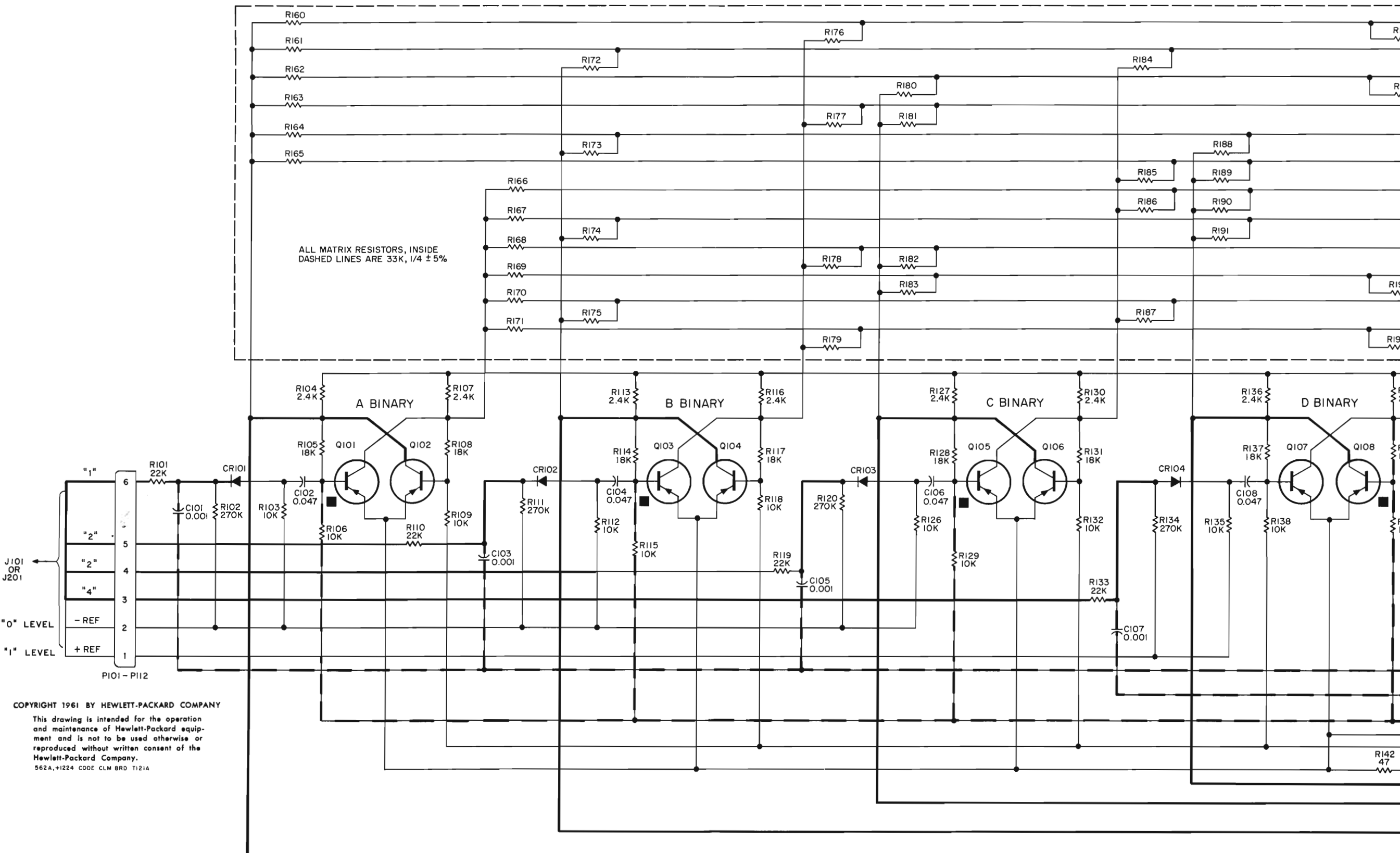

COPYRIGHT 1961 BY HEWLETT-PACKARD COMPANY

This drawing is intended for the operation and maintenance of Hewlett-Packard equipment and is not to be used otherwise or reproduced without written consent of the Hewlett-Packard Company.

562A, +1224 CODE CLM BRD T121A

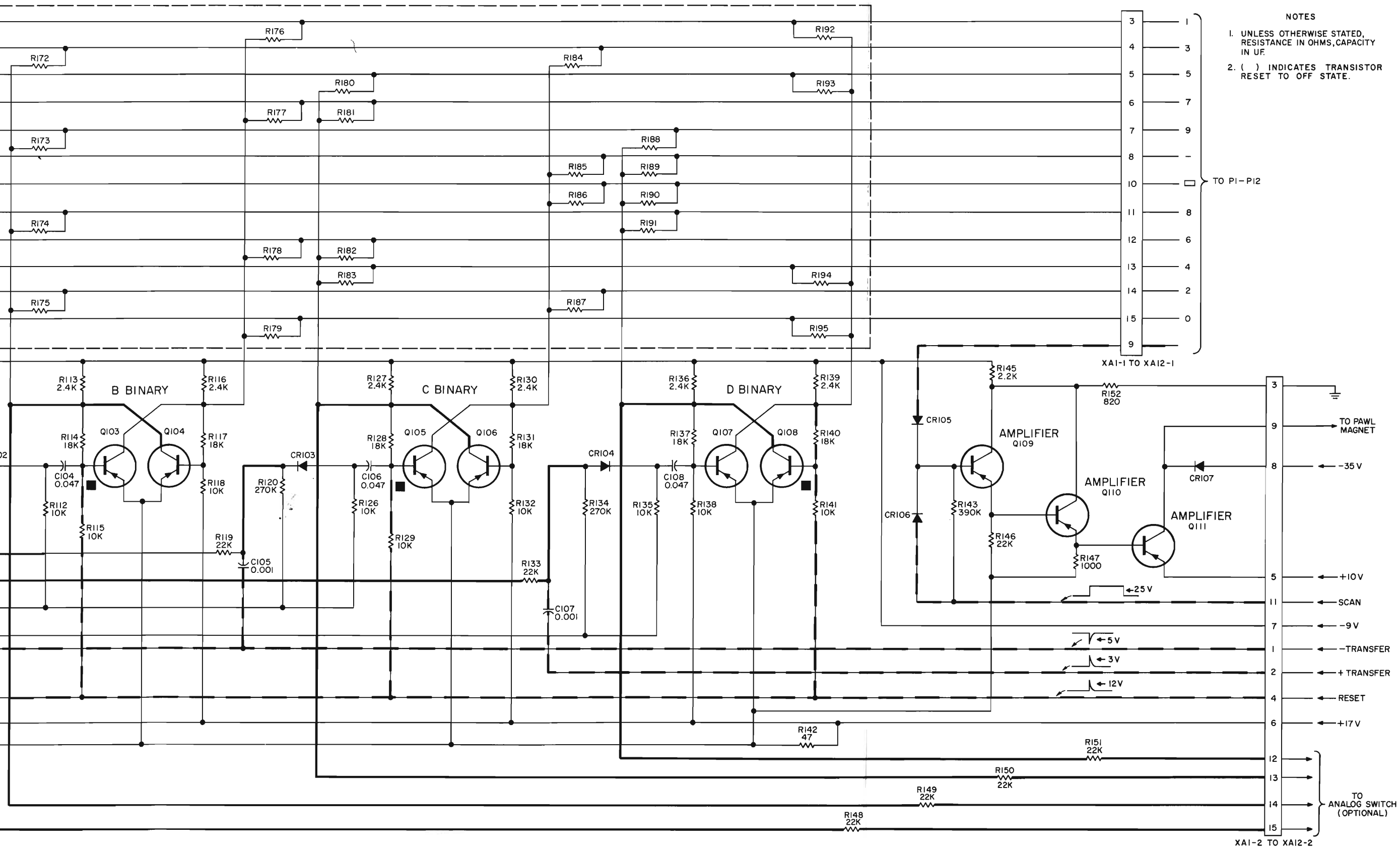

NOTES
 1. UNLESS OTHERWISE STATED, RESISTANCE IN OHMS, CAPACITY IN UF.
 2. () INDICATES TRANSISTOR RESET TO OFF STATE.

REFERENCE DESIGNATORS
 C101 - C108
 J1 - J12, J21 - J32
 P101 - P112
 Q101 - Q111
 R101 - R120, R126 - R143,
 R145 - R152, R160 - R195
 CR101 - CR107

Figure 5-10
+1224 Code Column Board



WARRANTY

All our products are warranted against defects in materials and workmanship for one year from the date of shipment. Our obligation is limited to repairing or replacing products (except tubes) which prove to be defective during the warranty period. We are not liable for consequential damages.

For assistance of any kind, including help with instruments under warranty, contact your authorized  Sales Representative for instructions. Give full details of the difficulty and include the instrument model and serial numbers. Service data or shipping instructions will be promptly sent to you. There will be no charge for repair of instruments under warranty, *except transportation charges*. Estimates of charges for non-warranty or other service work will always be supplied, if requested, before work begins.

CLAIM FOR DAMAGE IN SHIPMENT

Your instrument should be inspected and tested as soon as it is received. The instrument is insured for safe delivery. If the instrument is damaged in any way or fails to operate properly, file a claim with the carrier or, if insured separately, with the insurance company.

SHIPPING

On receipt of shipping instructions, forward the instrument prepaid to the destination indicated. You may use the original shipping carton or any strong container. Wrap the instrument in heavy paper or a plastic bag and surround it with three or four inches of shock-absorbing material to cushion it firmly and prevent movement inside the container.

GENERAL

Your authorized  Sales Representative is ready to assist you in any situation, and you are always welcome to get directly in touch with Hewlett-Packard service departments:

CUSTOMER SERVICE

Hewlett-Packard Company
395 Page Mill Road
Palo Alto, California, U.S.A.
Telephone: DAvenport 6-1755
Direct Dial Area Code 415
TWX No. PAL AL 117-U
Cable: "HEWPACK"

OR (In Western Europe)

Hewlett-Packard S.A.
Rue du Vieux Billard No. 1
Geneva, Switzerland
Telephone: (022) 26. 43. 36
Cable: "HEWPACKSA"



MANUAL CHANGES

MODEL 562A

DIGITAL RECORDER

Serials Prefixed: 134-
Manual Printed: 9/61

The following changes adapt this manual to instruments having the serial prefixes listed below:
(Ch. # = Change Number; Ser. Pre. = Serial Prefix)

Ch. #	Ser. Pre.	New Data
1	134-	On the Column Board schematics, The scan signal should be a negative going 25 volt signal. Resistors R106, 109, 115, 118, 129, 132, 138, and 141 have been changed to <u>4.7K</u> . Change R142 to <u>22 ohms</u> .
2	134-	On the Control Board, (Figure 5-5) R221 should read <u>68 ohms</u> . R222 should read <u>68 ohms</u> . R279 should read <u>560 ohms</u> . Resistor R287 should return to the reset line instead of the +17 volt line.
3	134-	On the Wiring and Power Supply diagram (Figure 5-3), Delete Fuse F1. Fuse F1 should be in the line coming from the upper half of the AC power plug. P301 and 302 should have the reference voltages applied to <u>pins 1 and 2</u> instead of pins 3 and 4. R303 should be changed to <u>100 ohms</u> .
4	134-	On the Analog Circuitry schematic (Figure 5-6), C406: Capacitor, 0.05 uf, should be added from the junction of R433-434 to ground. Change C406 to <u>C407</u> . The 2.4V breakdown diode should have the reference designator CR422. J501: The wires from pins 17 and 18 should be reversed. Change R40 to <u>R409</u> . Change R49 to <u>R439</u> . R349 should be changed to <u>1.8K</u> . R434 should be changed to <u>2.5K</u> . R442 should be changed to <u>6.8K</u> . R446: Resistor, 470 ohms, should be added from -9 V to ground on the analog board. Change R415 to <u>R415A</u> and R416 to <u>R415B</u> . Total resistance of both resistors is factory adjusted to 303K. Change R417 to <u>R417A</u> and R418 to <u>R417B</u> . Total resistance of both resistors is factory adjusted to 606K. Change R419 to <u>R419A</u> and R420 to <u>R419B</u> . Total resistance of both resistors is factory adjusted to 606K. Change R425 to <u>R425A</u> and R426 to <u>R425B</u> . Total resistance of both resistors is factory adjusted to 1,212 megohms. On all sections of S5, Change pin 15 to <u>12</u> , 14 to <u>13</u> , 13 to <u>14</u> , and 12 to <u>15</u> .

Ch. #	Ser. Pre.	New Data
5	134-	Addition to text: At the rear of the recorder, an interlock switch, S2, has been installed. When the back of the recorder is removed, fan motor B1 stops.
6	147-	This manual applies with the above changes.



OPERATING AND SERVICING MANUAL

FOR

SPECIFICATION H19-562A/AR

DIGITAL RECORDER

Specification H19-562A/AR is similar to the standard Model 562A/AR Digital Recorder. This special instrument has been modified as follows:

1. The twelfth column covered in the Operating and Service Manual for the 562A/AR has been added to this instrument.
2. Special print wheels have been installed in columns eight and nine. The columns are numbered from right to left when facing the front of the instrument. The characters on the print wheel are shown in the following table along with a standard wheel for reference purposes.

COLUMN NUMBER	STOCK NUMBER	PRINT WHEEL CHARACTERS
1 through 7	562A-95B **	1 3 5 7 9 - 8 6 4 2 0
8	562A-83E-1713	1 3 5 7 9 - + 8 6 4 2 0
12	562A-83E-1707	A C E G I K L H F D B J
10, 11, 12	562A-95B **	1 3 5 7 9 - 8 6 4 2 0

** Standard wheel; normally supplied.

In all other respects this instrument is electrically identical to the standard Model 562A/AR Digital Recorder and the information in the Operating and Service Manual for the standard instrument applies to this special instrument.

Encl:

562A
Print. Mech.
12 clmn

maa 362

SPECIAL PARTS FOR 12-COLUMN PRINTER MECHANISM -

The following changes have been made in the twelve-column printer mechanism in this special instrument. These changes apply to the Replaceable Parts Tables and their associated illustrations in the Operating and Service Manual for the Printer Mechanism.

ITEM	DESCRIPTION	Ⓟ STOCK NO.	TQ*	RS*
Page 5-10 -----				
1	Wheel bank, complete	† Special	1	1
2	Nut, print wheel shaft	561A-57A	1	0
3 thru 10	No change in description or Stock No.; increase quantity to twelve.	-----	12	-
11	Shaft, print wheel	561A-37B	1	0
12	Washer, shouldered	561A-88A	1	1
14	Washer, spring retaining	561A-88B	1	1
Page 5-12 -----				
23	No change in description or Stock No.; increase quantity to fourteen.	-----	14	2
Page 5-14 -----				
14	Print bar	561A-107A	1	1
Page 5-20 -----				
1	Pawl magnet assembly, complete	† Special	1	1
2	Magnet adjust plate	561A-12A	1	1
3	Pawl-holder bar	561A-107B	1	0
4	Pawl assembly (rivited assembly including flat spring, 12 armatures, and 12 pawls).	† Special	1	1
5, 6	No change in description or Stock No.; increase quantity to twelve.	-----	12	2
7	Magnet frame subassembly (includes yokes and cores)	† Special	1	0

† Special items do not have an Ⓟ stock number. To obtain replacements, order by description and instrument model number.

* See introduction to SECTION V in the Operating and Service Manual for the Printer Mechanism.

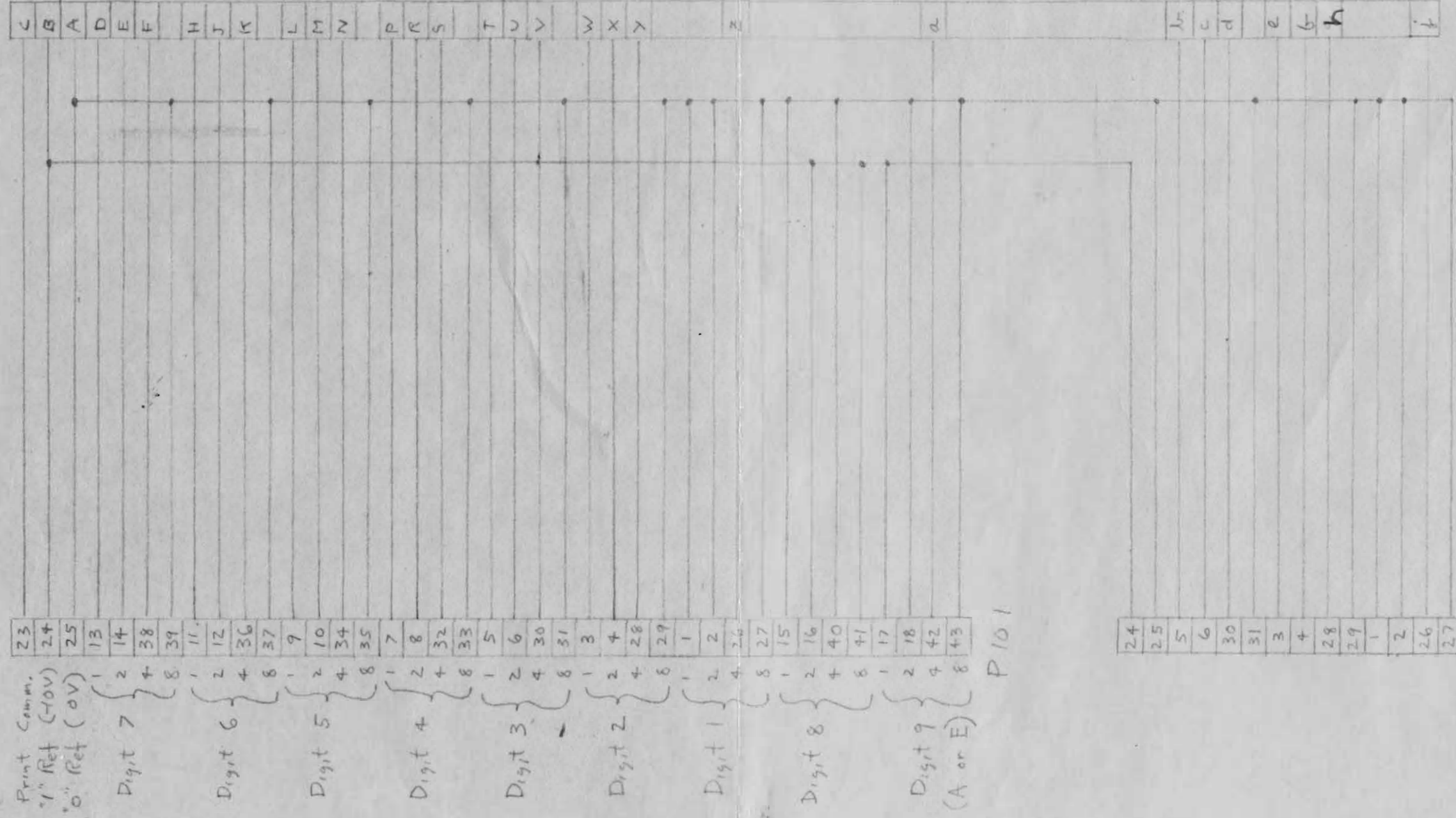

Amphenol
57-70500
Printer
Connectors

Output
C.E. C
Connector: 500C-42PI-J-SH

PRINTER CABLE
1.4.6.2.7 P

D Ruck 5-27-62